

Reprinted from 2010

MSC



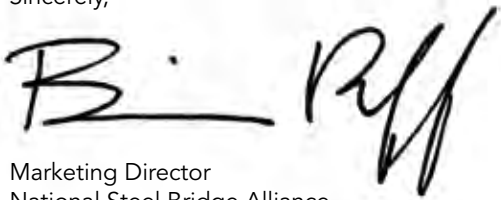
Steel Bridges 2010

Welcome to Steel Bridges 2010!

This publication contains all bridge related information collected from *Modern Steel Construction* magazine in 2010. These articles have been combined into one organized document for our readership to access quickly and easily. Within this publication, readers will find information about Accelerated Bridge Construction (ABC), analytical monitoring tools, weathering steel solutions, bridge renovation and repair, and art-inspired structures among many other interesting topics. Readers may also download any and all of these articles (free of charge) in electronic format by visiting www.modernsteel.org.

The National Steel Bridge Alliance is dedicated to advancing the state-of-the-art of steel bridge design and construction. We are a unified industry organization of businesses and agencies interested in the development, promotion, and construction of cost-effective steel bridges and we look forward to working with all of you in 2011.

Sincerely,



Marketing Director
National Steel Bridge Alliance

Table of Contents

March 2010: <i>Quick Change from Truss to Girder</i>	3
March 2010: <i>Steel Solution Speeds Bridge Repair</i>	6
March 2010: <i>Steel Interchange Solution Saves Millions</i>	8
April 2010: <i>Short, Wide and Heavy-Duty</i>	9
June 2010: <i>A Long-Span Connection</i>	11
June 2010: <i>Fast-Tracked Bridge Design</i>	14
June 2010: <i>An Analytical Monitoring Tool for Bridge Construction</i>	18
June 2010: <i>Getting Across Campus</i>	23
July 2010: <i>On a Beautiful Tilt</i>	26
July 2010: <i>Real-Life Lessons</i>	32
August 2010: <i>The Road to Repair</i>	35
September 2010: <i>Emergency Renovation</i>	38
September 2010: <i>Artistic Flyover</i>	42
September 2010: <i>Lift, Slide, Attach, Repeat</i>	46
October 2010: <i>Trading Up</i>	50
December 2010: <i>Highway Braid Made from Steel</i>	54
December 2010: <i>New Spans Over Two Oregon Rivers</i>	58
December 2010: <i>Economical Bridge Replacement</i>	62



Quick Change from Truss to Girder

The new Granite City Crossing Bridge in St. Cloud, Minn., crosses the Mississippi River with three deep continuous steel spans. The girder depth is 104 in. at midspan and 168 in. at the piers.

BY MANJULA LOUIS, P.E.

Extra effort and teamwork replaced the aging Desoto Bridge in surprisingly short order.

LOCATED 75 MILES NORTHWEST of Minnesota's capital, the Desoto Bridge in St. Cloud, Minn. for more than 50 years carried Highway 23 over the Mississippi River. The in-place truss bridge was built in 1957 and was named after Hernando Desoto, the first European to take credit for seeing the Mississippi River in 1541.

Following the I-35W bridge collapse in August 2007, one of the FHWA directives was to inspect all under-deck truss bridges. The Desoto Bridge was closed to traffic in March 2008 when minor distortion was found on a few of its gusset plates. Further analysis showed that the gusset plates had adequate strength but free edge stiffening would be required to remedy the minor distortions. The bridge was scheduled for replacement in 2010, but with these findings the district and the city decided to leave the bridge closed while accelerating design and construction so that a new bridge could be opened to traffic by November 2009. That required completing the preliminary and final design in a very short time—what typically would require 12 to 18 months had to be accomplished in less than two months.

Bridge Overview

Several options for spanning the river were considered, including prestressed concrete beams, post-tensioned concrete box girders, and continuous steel girders. In order to limit the number of piers

in the river, which was a key issue in obtaining permitting, a continuous steel girder bridge was selected. An additional consideration for the selection was the Minnesota Department of Transportation (MnDOT) Bridge Office's experience with steel plate girder bridges of this length. Using this in-house expertise was helpful in limiting the time required to create construction documents.

The new bridge spans the Mississippi River with three continuous steel spans of approximately 222 ft, 345 ft, and 222 ft. For the river spans, the haunched plate girder web depth varies from 104 in. at mid-span to 168 in. over the supports. An additional 92-ft span crosses Riverside Drive on the north side of the river and uses 36-in. rolled beams.

Construction Contracts

The bridge was let in two contracts. To ensure timely fabrication and delivery of the girders, an early steel contract was let on June 6, 2008, which provided additional time for steel procurement and fabrication. Upon award of the contract, the successful fabricator was to purchase the material, fabricate, and deliver the steel girders for the bridge to the project site by the date specified in the construction documents.

As completion of the project was tied to the on-time delivery

Upper: The truss that was the old Desoto Bridge's 145-ft center "drop-in" span was lowered intact onto a barge for removal.

Lower: Even though the girders are made of weathering steel, a 5-ft section at the support end was painted with a zinc-rich epoxy paint system to provide additional protection against corrosion.



Manjula Louis, P.E., is bridge design unit leader in the Oakdale, Minn., office of the Minnesota Department of Transportation's Bridge Office. She holds a master's degree in civil engineering from the University of Minnesota. Her responsibilities include preparation of plans and specifications for bridges and miscellaneous structures performance of other structural design services for the state highway system.

of steel, a monetary deduction of \$20,000 per calendar day was included in the contract for any material that did not meet the delivery schedule. The steel contract plans were sent to NSBA for distribution to interested fabricators. The steel contract was awarded to Chicago-based Industrial Steel Construction, Inc.

The final construction contract was let on July 25, 2008. To ensure opening of the bridge for traffic by November 1, 2009 a "Locked In Date" incentive of \$1,000,000 was added. The final contract was awarded to Lunda Construction Company, Black River Falls, Wis. The total construction cost of the project was \$19.5 million. The steel portion of the contract was \$7,278,000.

Design Considerations

Final bridge plans and the specifications were completed in 55 days. This required close coordination with the city's visual quality task force, the geotechnical engineers for the river foundation coordination, and the local contractors for input on bridge demolition and conflicts between existing and new river pier foundations. The existing deck removal was done by saw cutting the deck and removing it in small sections. The pieces were dropped onto a barge to minimize damage to the riverbed. The in-place truss had a "drop-in" span about 145 ft long at the center of the bridge that was lowered intact onto the barge. Even though that was not the most efficient method for removing the truss, it had the least impact on the river channel. The 220-ft-long approach spans were supported on temporary falsework for stability and removed in sections by barge.

More than 20 engineers and drafters from MnDOT's Bridge Office were involved in completing the bridge design and construction documents. Daily meetings were held to coordinate the work done by team members in different functional groups. To meet the schedule, final design was started at the same time as the preliminary plan group was finalizing the roadway alignment and profile. Visual quality and environmental assessment are normally critical path items as they require input from outside agencies and citizens. The Bridge Office already was working with a citizen advisory committee on the visual quality aspects of another bridge of significance in the area. Due to the proximity of Desoto Bridge to that bridge, the committee decided to use the same aesthetic details. A categorical Exclusion Document was put together in place of an Environmental Assessment document due to minimal environmental impact in the river.

Substructure Design

A geotechnical consultant contract for subsurface investigation and completion of the foundation report was let in April 2008. Design and drafting of the substructures was started ahead of foundation recommendation. The foundations were designed based on existing soil borings and pile records and had to be revised as new borings were completed. To minimize revisions and rework, the normal process of drafting substructures foundations on up, a top down process was utilized.

Foundation recommendations were completed in June. The borings indicated dense granular soils in the top layers followed by dense loamy soil at all substructure locations except Pier 2. At Pier 2 granite rock was encountered at depths varying from 15 ft to 30 ft from the bottom of the footing. The west abutment, Pier 3 and east abutment are supported on spread footings, Pier 1 is on H-piling, and Pier 2 is on rotary drilled cast-in-place concrete piles.

Due to the proximity of the rock layer at Pier 2, the cofferdam design was challenging. Lowering the water level in the river by using the dam downstream was considered to meet the factors of safety required by MnDOT. But ice build-up in the river made this an unreliable option. The seal thickness varied from 10 ft to 16 ft and the seal design was revised using average thickness.



left, top: The haunched section of this interior girder shows the longitudinal stiffeners that were required at the river piers.

left, middle: Lateral bracing was included to resist wind loads during construction.

left, bottom: The 92-ft span over Riverside Drive, on the north side of the river, uses 36-in. rolled beams. The deeper girder ends are visible to the left of the support.



Superstructure Design

Special deck design considerations were required due to a deck span of 15 ft, 6 in. and the addition of overlook areas. The pier overlooks were supported using steel plate brackets fanning from the girder stiffeners.

The delivery schedule for steel plates and the availability of high-strength steel were discussed with NSBA, which suggested not using high-performance steel due to uncertainty in steel delivery schedule.

The plate girder used two different web thicknesses— $\frac{3}{4}$ in. for outer spans and over the river piers and $\frac{1}{16}$ in. for the middle span between the river piers. Longitudinal stiffeners were required over the river piers. The thickness of the flanges varied from $\frac{1}{4}$ in. to $\frac{3}{4}$ in. Lateral bracing was required to resist wind loads during construction.

The bridge also carries a 24-in. water main hung underneath the deck that required special diaphragm details. Haunch girders and the presence of the water main resulted in seven different types of diaphragms. Weathering steel was used for the girders, which is MnDOT's standard practice. The end 5 ft of the beams are painted with a zinc-rich epoxy paint system to provide protection against corrosion. Also, the exposed face of fascia girders was painted to meet visual quality requirements.

Conclusions

A project this size typically requires 12 to 18 months for completion and the final design is normally handled by a group consisting of a principal engineer, two senior engineers and four drafters. Thanks to very good coordination between various agencies and district offices, using more than 20 engineers and drafters made the delivery of this project possible in less than two months. Also, by letting the project in two contracts, the early steel contract provided additional time for steel procurement and fabrication.

Steel proved to be cost competitive for this project, and the cost of replacing the Desoto Bridge was well below MnDOT estimates. The bridge opened to traffic on October 29, 2009, renamed the Granite City Crossing Bridge to pay tribute to the many granite quarries found in the vicinity.

MSC

Owner

Minnesota Department of Transportation

Structural Engineer

Minnesota Department of Transportation – Bridge Office

Steel Fabricator

Industrial Steel Construction, Inc., Chicago (AISC Member)

General Contractor

Lunda Construction Company, Black River Falls, Wis. (IMPACT Member)



Fast track replacement of deteriorated span quickly gets vehicles back on the road.

Steel Solution Speeds Bridge Repair

BY CHUCK MERYDITH

High Steel Structures, Inc.

WHEN A ROUTINE INSPECTION of the Route 90 Bridge over the Assawoman Bay in Ocean City, Md., revealed previously undetected structural damage at the bridge's navigational span, the Maryland State Highway Administration (SHA) closed the bridge for emergency repairs.

Work on the 85-ft portion of the bridge, which carries 18,000 vehicles into the popular beach resort each day, was anticipated to finish in mid-December. But the bridge reopened on November 24, three weeks early and just in time for the Thanksgiving holiday.

"We were delighted that repairs were completed not only on time, but ahead of time," said Ocean City mayor Rick Meehan. "This benefits the business community and is a vital safety improvement."

The damaged section of the bridge was discovered during a biannual inspection that showed serious deterioration of the concrete of one of the girders, exposing the reinforcing steel to corrosion.

Chuck Merydith, APR, CBC, is a marketing communications consultant with Merydith Communications, based in Oak Park, Ill.

Concern about the ability of the bridge to carry truck loads initially prompted the restriction of vehicles over 6,000 lb. It was quickly determined that the one span of the 38-year-old bridge could not be repaired. Instead, it needed to be closed and the section replaced immediately in order to restore the bridge's capability to carry truck loads as soon as possible.

"A steel girder superstructure was selected for the span replacement, because it weighed less than other replacement alternatives," said Will Pines, P.E., Maryland SHA's project manager. "This weight reduction onto the existing bridge allowed for more of the bridge to be preserved, thus cutting back on repair costs."

Fabricator High Steel Structures, Inc., Lancaster, Pa., expedited procurement for steel fabrication and delivery of the replacement girders. High Steel was given notice to proceed on October 6, while the design was being finalized and the contractor was mobilizing. Due to the fast track approach, the first shipment of steel arrived at the jobsite on October 27.

"High Steel had the resources available in both material needs and manpower to fit this project into the shop flow, waiving the standard lead times," said Paul Lipinsky, High Steel project manager. "Having the material already on hand allowed us to dramatically cut fabrication time and begin delivery of the steel only three weeks after we were given notice to proceed."

High Steel's engineering department worked closely with the designers and the Maryland SHA to expedite the design and detail

Opposite page: The first shipment of steel arrived on the job just three weeks after the fabricator was given the notice to proceed, and two months later the bridge was back in service.

Right: Deterioration of concrete girders forced the closing of one of only two bridges crossing from the mainland to Ocean City, Md. Using a steel superstructure enabled its quick replacement and reduced the cost of repairs.

drawings approval process. A fabrication project manager was assigned to shepherd the project through fabrication.

In addition to the quick fabrication and delivery of the replacement superstructure, the SHA credits several additional factors for the project's early turnaround, including the contract's incentive/disincentive clause and a powerful nor'easter that tore through the area in early November. The crew raced to place the concrete deck a day before the storm struck, averting a potential one-week delay.

The contractor built the replacement span using the "Cape Fear," a 150-ton water rig friction crane. The crane, mounted on a 68-ft-wide barge, accessed the bay through careful navigation through the 78-ft draw-bridge span of the Route 50 Harry Kelley Memorial Bridge, the only other bridge access to the Ocean City barrier island from the mainland. The strong currents and meandering channel at the Route 50 Bridge provided even more of a challenge than the narrow clearance.

By mobilizing the large floating crane, the contractor was able to expedite removal of the span by lifting it out in just five pieces. Its high capacity allowed removal of pieces with girders, deck and parapets still intact. The crane also allowed erection of the fascia girders in pairs with all of the deck overhang formwork pre-installed.

In a letter to High Steel's president, Jeffrey Sterner, P.E., Earle Freedman, director of SHA's Office of Structures, thanked High Steel for its fast response, citing a similar situation on the Old Severn River Bridge that occurred in 1979.

"It is extremely comforting to have a relationship with a firm like yours," wrote Freedman. "We called upon High Steel then, as we did now. A positive reaction by your firm to a similar problem, 30 years later, is a true example of why your firm continues to have such a fine reputation." MSC

Owner

State of Maryland

Steel Fabricator

High Steel Structures Inc., Lancaster, Pa.
(AISC and NSBA Member)



images courtesy of High Steel Structures, Inc.



The contractor's use of a large crane expedited removal of the deteriorated span and allowed placement of the steel fascia girders in pairs with the deck overhang formwork pre-installed.

Replacing ramps with flyovers quickly alleviates highway congestion.

Steel Interchange Solution Saves Millions

BY CHUCK MERYDITH



Augusta Iron & Steel Works Inc.

ONE OF NEWEST highway interchange upgrades around Augusta, Ga., the I-20/I-520 interchange on the Bobby Jones Expressway, posed a significant challenge—design and reconstruction of a new interchange configuration in an already developed urban area. The construction staging and maintenance of traffic were very complex, and steel was the material of choice for the solution.

“This project featured two huge flyovers, originally designed as concrete boxes,” said Bo Bovard of Augusta Iron & Steel Works, Inc., Augusta, Ga., which fabricated the steel. “However, we promoted steel as an alternative to the concrete design because we thought it would save the taxpayers significant money and provide faster and safer construction methods. We used NSBA’s design study to prove it.”

The original I-20 bridges, built in the early 1980s, were steel, but improvements such as widening were long overdue. Also, the original intersection where I-20 goes over I-520 was a standard cloverleaf with tight loops on all four corners. Two of those have now been replaced with flyovers featuring superelevated curves to better handle the heavy traffic volume.

“We used a value-engineering proposal,” said Ike Scott, president of the joint venture partner Scott Bridge Company Inc., Opelika, Ala. As a result of the change to steel, taxpayers saved roughly \$4 million.

“The overall road widening project took 3½ years, but the re-design of the bridges from concrete to steel saved a considerable amount of construction time,” Scott continued. “The acceleration in the bridge reconstruction allowed our joint venture partner, United Contractors, Incorporated of Great Falls, S.C., to double and triple their roadway crews to finish the project early. Their efforts were critical to the overall success of the project.

“We redesigned the superelevated curved ramp bridges from reinforced post-tensioned concrete boxes to curved structural steel I-girders,” Scott said. “When the Georgia Department of Trans-

The recently reconstructed I-520/I-20 interchange near Augusta, Ga., includes flyover connections in place of two tight curves which has greatly increased its capacity.

portation project was first designed in the late 1990s, the labor market was not as tight as when the job was finally bid in 2007. The redesigned structural steel required less labor but performed well even though the fabrication and erection were challenging. There were no problems with the installation and there was also minimal site and traffic disruption. It’s now a beautiful interchange for the traveling public.”

“This was an amazing project because they finished almost one year ahead of schedule,” said Bill Kuhlke, chairman of the Georgia State Highway Board. “It was especially critical for us to have the interchange open last April for our most important event of the year—the Masters.

“Much of the credit for this effort goes to Scott Bridge Company,” he continued. “This project is certainly one of the best highway improvement projects in the state of Georgia.” **MSC**

Chuck Merydith, APR, CBC, is a marketing communications consultant with Merydith Communications, based in Oak Park, Ill.

Owner

Georgia Department of Transportation

Joint Venture Partners

Scott Bridge Company Inc., Opelika, Ala., and United Contractors, Inc., Great Falls, S.C.

Steel Fabricator

Augusta Iron & Steel Works, Inc., Augusta, Ga. (AISC and NSBA Member)

Short, Wide and Heavy-Duty

BY DENNIS MARTINEZ, P.E. AND JAMES ROSALES, P.E.

Weathering steel fits unique need for two new airport taxiway bridges.

TWO NEW STEEL TAXIWAY BRIDGES were opened in January at the Charlotte Douglas International Airport (CLT) as part of the airport's new 9,000-ft parallel runway project. The bridges for taxiways November and Sierra carry aircraft over future railroad tracks and access roads that are part of the future inter-modal facility on the airport.

Two types of superstructures, steel plate girders and prestressed concrete beams, were considered for this project. Aircraft wheel design configurations limited the design beam spacing to 3 ft to account for present and future aircraft landing gear wheel configurations. The major factor in the selection of steel plate girders was attributed to the reduced gross superstructure weight, compared to the concrete option, that consequently reduced the loads on the substructure elements.

And where the steel plate girders provided a simple and conventional design, using prestressed concrete beams would have required a non-conventional approach, such as beam section modifications. To offset maintenance costs associated with steel bridges and in particular the number of steel elements for these bridges,

Relatively short compared to their widths, the two new taxiway bridges at the Charlotte (N.C.) Douglas International Airport feature steel girder superstructure that made their construction quick and easy, and enabled their opening three months ahead of schedule.

Grade 50 weathering steel was selected.

Approximately 2,100 tons of structural steel was used and total project cost was close to \$19 million. Construction began in November 2008. The use of steel plate girders for the superstructure made for quick bridge erection—all structural steel was delivered and put in place in approximately 10 days per bridge, which contributed to the opening of the bridge taxiways three months ahead of schedule. One key factor was the ongoing communication and cooperation between the steel fabricator and the contractor.

Dennis Martinez, P.E., has been active in a variety of transportation engineering projects including the design of bridges, retaining walls, bridge ramps, bridge restoration, and bridge extension projects. His recent experience has included a vast amount of successful transportation improvement projects including major highways, interchanges and bridge structure design.

James Rosales, P.E., is actively involved in the structural design/inspection and preparation of specifications on various airport improvement projects, including airfield engineering, specialty structures such as passenger loading bridges, tunnels and related infrastructure and utilities.



Opened in January 2010, the new Charlotte Douglas International Airport taxiway bridges are designed to handle today's heaviest aircraft and to maintain full capacity across the width of the bridge.



Bo Bovard, president of Augusta Iron & Steel said, "This project was a great example of outstanding teamwork between the contractor and our company that gave us the opportunity to finish ahead of schedule. We're also gratified that T.Y. Lin recognized the superior performance of steel in this type of specialized application."

"Thanks to the contractor's continuous efforts to keep us informed of their requirements, we were able to provide the steel when they needed it," said Augusta Steel & Iron executive vice president Al Metzler. "Their professionalism was critical to the success of this project."

Designing airport bridges is much more complicated than designing traditional highway bridges. Designers must consider requirements related to bridge geometry, aircraft loading and the Federal Aviation Administration requirements. The structure was designed to maintain full capacity across the width of the bridge to account for the event of an errant aircraft. Curb and parapets were provided at the edges to help redirect drainage to the bridge ends. Taxiway centerline and edge lighting were provided along the deck and approach slabs.

The Taxiway Sierra bridge required a span length of 91 ft, 6 in. and a bridge width of 217 ft. The Taxiway November bridge similarly required a bridge width of 217 ft, but required a shorter span length of 77 ft, 6 in. Plans for an additional future railroad track resulted in the increased bridge length for the Taxiway Sierra bridge. Bridge width geometry required compliance with the taxiway safety area requirements for Design Group V aircraft, which includes aircraft with wingspans up to 214 ft. The Boeing 747-400, Boeing 777 and Airbus A340 are some of the heaviest aircraft included in Group V.

For final design, the superstructure for both bridges consisted of a 13-in. reinforced concrete deck acting compositely with plate girders through the use of shear connectors. Framing consisted of 72 lines of plate girders at 3-ft spacing. The girders on Taxiway

November and Taxiway Sierra maintained a constant web depth of 72 in. and 80 in., respectively. Intermediate cross frames consist of single angle $4 \times 3 \times \frac{7}{8}$ members located diagonally between girder webs. Use of a single diagonal member provides access for facilitating field inspection.

End diaphragms at support locations consist of W24x68 members for the top bracing and C15x33.9 for the bottom bracing. The end diaphragm configuration provides access for inspection on the back side of the end diaphragms members in front of the abutment backwall. Approach slabs 30 ft long and 30 in. thick were used to help reduce local settlement and provide a gradual transition between the taxiways and the bridge decks.

The substructure consists of concrete abutment walls supported on spread footings for the Taxiway November bridge. The concrete abutment walls for the Taxiway Sierra bridge are supported on battered HP14x117 steel piles. The presence of bedrock under the footings for the Taxiway November bridge provided the required bearing capacity for spread footing foundation. Aircraft surcharge loading including braking forces resulted in concrete abutment walls with a thickness of $4\frac{1}{2}$ ft at the base. Seismic loading was not a controlling factor because the bridges are located in a low seismic zone. Mechanically stabilized earth wing walls were designed at both ends of the abutment walls to accommodate the grading requirements of the project.

MSC

Owner

Charlotte Douglas International Airport

Structural Engineer

T.Y. Lin, Miami

Steel Fabricator

Augusta Iron & Steel Works, Inc., Augusta, Ga.
(AISC and NSBA Member)



NATIONAL STEEL BRIDGE ALLIANCE

Steel Bridge NEWS

JUNE 2010

A new high-strength weathering steel girder bridge now crosses the flood-prone Pemigewasset River.

A Long-Span Connection

BY WADE BROWN, P.E.

Laura Parent

FOR NEARLY TWO CENTURIES, a bridge of some variety has spanned the Pemigewasset River, connecting the communities of Bristol and New Hampton, N.H. The latest structure, which opened to traffic in September 2009, holds the distinction of being the longest single-span bridge of its kind in New Hampshire.

The new Central Street Bridge features 8-ft-deep high-strength weathering steel girders spanning 240 ft. The bridge also features a steel bracing system that will help the structure resist floodwater forces, a regular challenge at this location. Already, the attractive structure is serving as a source of civic pride for the towns it connects.

The \$4.7 million Central Street Bridge replaces a structure that opened in 1928. The old structure consisted of a High Parker truss with a polygonal top chord. The single-span, 245-ft-long, 18-ft-wide bridge was deemed “functionally obsolete” by the New Hampshire Department of Transportation several years ago.

Several interior steel diaphragms on the new Central Street Bridge are designed to transfer the force of floodwaters to each end of the bridge where it is resisted by steel restraint members embedded in each abutment just downstream from the third girder.

Wade Brown, P.E., is a principal engineer with Kleinfelder/S E A Consultants, Manchester, N.H. He can be reached at wade.brown@seacon.com.



An earlier bridge succumbed to a more violent end. That structure opened in 1836 and was a two-span, covered truss bridge with a single stone pier near the center of the river. It fell victim to the Pemigewasset's ongoing floodwaters in March 1928.

Designed to Resist Floods

The river's penchant for flooding was a significant consideration during the design phase of the new bridge. The weight and depth of the girders were reduced through the use of high-strength (Grade 70) steel. This particular design element created a more slender and streamlined appearance, and allowed using smaller cranes to erect the girders. More importantly, however, it served to increase the clearance above the Pemigewasset by approximately 4 ft, while the elevation of the roadway was raised by approximately 10 ft.

Even so, the bridge was designed to resist floodwater forces that would result from a breach of the upstream Ayers Island hydroelectric dam. The force resisting system includes several interior steel diaphragms designed to transfer the floodwater force from the upstream girder to the concrete bridge deck. The bridge deck, acting as a rigid horizontal diaphragm, collect the force from each interior diaphragm and transfer it equally to each end of the bridge. There the steel end diaphragms, between the girders, collect the total force and transfer it down to a 3,000-lb structural steel restraint member embedded in the concrete abutment. This restraint member is located just downstream from the third of four bridge girders. A small gap separates the girder from the steel restraint block. This gap will close as the girder's steel reinforced elastomeric bridge bearing deforms transversely from the floodwater force.

Minimizing Impacts

In order to minimize construction and permanent impacts to the steeply sloping western river bank, the abutment was designed with tall, curved wingwalls that step up into the hillside. The walls, 60 ft in length and up to 42 ft in height, are curved to parallel the roadway approach and minimize side impacts. The footing is stepped in increments of 13 ft, which significantly reduced the cost of reinforced concrete, rock excavation, and temporary earth retention.

While usually a temporary system, the steel sheet piles used for the west abutment cofferdam were designed to remain in place by anchoring to a 6-in.-thick reinforced concrete sub-footing, and serve as permanent scour protection for the abutment's footing.

An Unforeseen Hurdle

The wars in Iraq and Afghanistan made the procurement of steel difficult during the bridge's construction period. Because one of two U.S. steel mills was engaged in tank production for the U.S. military, the other mill was faced with an overload of domestic orders, which resulted in a delay to the project. The high-strength (Grade 70) rolled plates, required to fabricate the steel plate girders, became available seven months late, which delayed steel fabrication and extended the steel erection phase of the project to beyond the following year's high-water season. Even with the delay, good management of the construction phase helped keep the total construction cost, including construction engineering, below the 2007 bid price.

The new Central Street Bridge has been designed to use low-cost, durable materials including elastomeric bridge bearings, weathering steel girders, silicone deck expansion joints, and

granite block retaining walls, that will keep maintenance costs at a minimum.

It also features level spreaders with stone fill to naturally treat stormwater runoff before it reaches the Pemigewasset. Plantings throughout the riprap stone slopes minimize the impact of absorptive heat transfer from the rocks to the river's waters. Shallow steel girders and tall abutments were included in the overall design, enabling visual separation of the bridge from the river and other natural aspects of the site. During construction, a new river access pathway was created, which features granite steps built with material recycled from the old bridge abutments.

Approaches to the old bridge contained steep grades and tight turns. When opposing cars would come across the bridge, one vehicle would typically need to stop for the other to pass. With the new bridge, realigned approaches, wider travel lanes (28 ft between curbs), flatter grades, softened curves, and a 6-ft-wide sidewalk means vehicular and pedestrian safety has been greatly increased.

With the new Central Street Bridge, the citizens of Bristol and New Hampton are not only getting a vital transportation link, but a durable and attractively designed structure that blends in majestically with the natural environment.

MSC

Owner

Municipalities of New Hampton, N.H. and Bristol N.H. (Funding assistance and oversight provided by the New Hampshire Department of Transportation.)

Structural Engineer

Kleinfelder/S E A Consultants, Manchester, N.H.

Steel Fabricator

Casco Bay Steel Structures Inc., Saco, Maine (AISC and NSBA Member)

Steel Detailer

Tensor Engineering, Indian Harbour Beach, Fla. (AISC and NSBA Member)

General Contractor

Winterset Inc., Lyndonville, Vt.



Laura Parent

Replacing a functionally obsolete truss bridge, the new Central Street Bridge connecting Bristol and New Hampton, N.H., is the longest single-span bridge of its type in the state.

A sophisticated, iterative analytical approach to re-evaluating the bridge superstructure has put this project on the path to completion.

Fast-Tracked Bridge Design

BY PRABHJEET RAJ SINGH, P.ENG., P.E., AND
MATTHIAS SCHUELLER, P.ENG., PH.D.

CROSSING THE MACKENZIE RIVER IN CANADA'S NORTH-WEST TERRITORIES IS ANYTHING BUT EASY. In summer a ferry provides a way across, and in winter passage is via an ice bridge. But during the transition seasons, as the ice is breaking up or before it freezes solid, neither option is available.

The Deh Cho Bridge now being constructed soon will provide a permanent link for ground transportation in the area. It is a composite steel truss bridge with a cable assisted main span. The structural system can be classified as a composite bridge with hybrid extradosed-cable stayed features. Comparable to a cable stayed system, the primary purpose of the cables is to support the truss in spanning the navigation channel. Cable stayed bridges use a close stay spacing to realize slender superstructures. However, contrary to a cable stayed system, the backstays on the Deh Cho Bridge are not anchored at a pier location. The backstays function by activating the bending stiffness of the truss similar to an extradosed system. This reveals the difference of an extradosed bridge and a classical cable stayed bridge in terms of the structural system.

The two-lane, nine-span bridge has main navigation span of 623 ft. The approach spans are symmetrical about the center of the

bridge. Each end begins with a 295-ft span followed by three 369-ft spans. The total length of the bridge is 3,427 ft. The superstructure consists of two 15-ft deep Warren trusses with a transverse spacing of 24 ft and a 9-in-thick precast composite deck.

The truss members are built-up I-sections. Two A-shaped pylons, located at Pier IV South and Pier IV North, each support two cable planes. Each cable plane consists of six cables connected to the main truss through an outrigger system. Figure 1 shows the bridge layout.

Design

The design philosophy adopted for the Deh Cho Bridge consists of the *big picture approach*, the *failure mechanism concept*, and the *integrity rule*.



Figure 1: General arrangement of the Deh Cho Bridge includes nine spans from 295 ft to 623 ft in length.



The Deh Cho bridge will provide a year-round means for crossing the Mackenzie River in Canada's Northwest Territories where until now access has been seasonally interrupted.

In adopting a *big picture* approach for the design of the Deh Cho Bridge, special consideration was given to functionality, safety, durability, constructability, cost, maintenance and aesthetics. Member profiles and materials were selected for their efficiency in resisting the primary force effects they experience. As an example, the bottom chord is an optimized I-profile resisting axial demands during service and in addition bending during launching. The dead load to payload ratio is minimized through the principles of lightweight design. The primary structural objective was to tune the system to be flexible for temperature

effects while at the same time being stiff for live and wind loads.

The *failure mechanism* concept was applied to ensure that the structure does not experience a sudden collapse under any given load scenarios. The primary load paths are designed for a controlled failure mechanism. The load travels through a series of structural components comparable to a structural chain. The weakest link in the chain is determined by the designer and engineered to fail with adequate warning (ductile behaviour).

The Post-Tensioning Institute (PTI) recommends that designers consider cable loss scenarios. For those extreme events the designer should ensure the *integrity* of the bridge is not endangered. Basically, the design engineer should have a clear understanding of the load path and load behaviour for various load combinations. In absence of a secondary load path, it is important to design the weakest member along the path with a ductile behaviour to signal an overload through visual deformations or at least partial damage prior to

collapse. For example, the cable anchorage and attachments are designed for the minimum breaking load of the cable, making the cables the crucial component of this particular load path.

Value Engineered Design

The principles of lightweight design led to a saving of 25% in the use of structural steel. The deck consist of precast concrete panels with cast-in-place infills. A combination of a waterproofing membrane with two layers of asphalt is applied to the surface for sealing purposes. The new deck is designed as a four-way slab resting on the truss and floor beams, thereby cutting the concrete mass by 30% and eliminating the need for pre-stressing.

The articulation scheme allows a continuous deck for the entire length of the superstructure, which eliminated the need for two modular deck joints on the bridge. The articulation scheme involves the use of modern lock-up devices, which act like shock absorbers to allow slow acting movements while restraining sudden force effects.

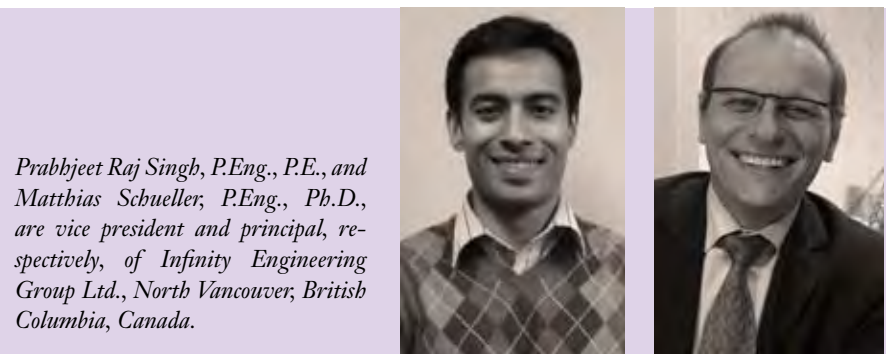
Proceeding With the New Design

Construction work on a major bridge crossing the Mackenzie River in Canada's Northwest Territories is again in full swing after being temporarily halted for an extensive redesign of the steel superstructure. The \$180 million (Canadian) crossing will provide a permanent connection across the river for the communities of Yellowknife and Ft. Providence to the lower highway system of Canada.

An independent review by T.Y. Lin International (TYLin) on behalf of the owner identified deficiencies in the original superstructure design. Infinity Engineering Group Ltd. was retained to propose conceptual solutions to eliminate the inadequacies with the original design. Infinity developed a redesign option for an extradosed steel truss bridge, the first of its kind in North America. A value engineering exercise showed this approach would result in significant savings in cost and schedule while simultaneously improving safety, durability, and constructability. In January 2010, Infinity completed the redesign in an accelerated six-month schedule that allowed the project to proceed.



Above right: A steel-armored reinforced concrete base in the Mackenzie River awaits erection of one of the Deh Cho Bridge's two A-shaped cable support towers. Photo: GNWT



Prabhjeet Raj Singh, P.Eng., P.E., and Matthias Schueller, P.Eng., Ph.D., are vice president and principal, respectively, of Infinity Engineering Group Ltd., North Vancouver, British Columbia, Canada.

Compact locked coil cables have been used for the stay system using a Galvan coating and cast sockets. The cables will be shipped to site in the final length but the adjustable anchorage at the superstructure allows for length variations to correct and manipulate cable forces. Compared to common strands, locked coil cables are slender with compact anchorage details. The condition of the outer wires and anchorages can be easily inspected visually. The locations of the cable anchorages were selected for improved structural and aesthetic behaviour. The simplified anchorages can be easily inspected and maintained.

Constructability aspects as well as a lightweight design approach have been adopted for the design of the superstructure and pylons. The design of the bridge incorporates a proven construction scheme.

A truss is an excellent candidate for lightweight design as it predominantly relies on compression and tension members to transfer loads. Making the trusses composite with the concrete bridge deck uses both elements to economic advantage. The principles of lightweight design require maximization of the payload to dead load ratio. This is achieved by minimizing the self weight of the bridge, primarily the concrete deck. In the case of the Deh Cho Bridge, the high live load factors and the dynamic load allowance of the Canadian Highway Bridge Design Code govern the concrete slab design. An average slab thickness of 8½ in. has been realized using Yield Line Theory.

Continuous Superstructure

A continuous superstructure avoids the use of expansion joints on the bridge and reduces the service and maintenance effort. The design objective of the deck was to engineer a continuous system over the entire bridge length. To achieve the goal the articulation scheme was required to allow temperature movements with minimal restraining effects and “lock-up” the movements during fast-acting load effects such as wind gusts in order to share the loads with several piers. The so-called “lock-up” devices (LUDs) mounted between superstructure and pier enable this articulation scheme. These devices are dampers with restrictive orifices; they only allow a significant translation when a certain force is applied over a period of several hours.

Constructability

The truss was engineered as a “Lego” system that is easy to fabricate and assemble. The chord member geometry was kept constant throughout the length of the bridge. The varying force effects were resisted through changing the steel strength and when necessary by boxing of the chord “I” section through the addition of side plates. Steel Grades of 350 AT and 485 AT have been specified for the truss. Open profiles were selected for the truss members for good access and assembly.

Analysis

The analysis undertaken for the project included: a global analysis of the entire bridge, an erection staging analysis and local finite element analyses for specific connections and details. For the global analysis of the bridge on LARSA 4D, a 3D model was created that included the entire bridge consisting of foundations, piers and abutments, bearings, truss, pylons, cables and deck. The salient features of the analysis are briefly described in this section.

Cable Tuning

The first step in the global analysis was to tune the dead load sharing in the truss and the cables to obtain a beneficial behaviour. An accurate estimate of the cable force was obtained by making

all the members infinitely stiff under dead load. The preliminary cable size was determined using the dead load cable force and a contingency for transitory loads. The properties of the cables thus determined were used in the model together with the real stiffness of all other members, compensating for the cable elongation by using a temperature load case.

Negative Camber

The span arrangement of the Deh Cho Bridge requires a truss camber at the cable support locations. The span supported by the back stays is only 112.5 m while the span supported by the front stays is 190 m. This uneven configuration results in unbalanced cable forces in the front and back stays, and thus causes a tower rotation to find equilibrium (see Figure 2). Because the back stays are not connected to a fixed point such as an anchor pier, typical for cable-stayed bridges, truss uplift at the backspan cable support cannot be compensated for by cable force manipulation.



Figure 2: Unbalanced system with dead load and cable tensioning applied.

To achieve the given roadway profile the truss needed to be cambered down (negative camber) in the backspan. The truss camber for half the bridge is shown in Figure 3.



Figure 3: The truss camber in the backspan helps compensate for the uplift introduced on that span due to the unbalanced cable stay load.

The truss camber shown in Figure 3 compensates for the permanent load deflections shown in Figure 2, resulting in the desired roadway profile (see Figure 4).



Figure 4: With the camber, cable shortening and dead load applied, the bridge deck profile is as planned.

Influence Surfaces

Influence surfaces were used to determine the maximum force effects from moving loads. An influence surface, or 3D grid of influence coefficients, is created by running a unit load over a pre-defined load area (typically traffic lanes). An influence surface can be generated for a force effect (i.e. bending, shear, compression etc.) at any cross section of a component of the structure. The magnitude of the force effect from a vehicle placed anywhere on the load area is determined from the influence coefficients and the vehicle loads.

Ultimately, the vehicle is positioned on the influence surface to maximize the force effects under consideration. The influence surface for the bottom chord in the center of hanging span can be seen in Figure 5. The corresponding deformation for a truck positioned in the most unfavourable location is shown in Figure 6.

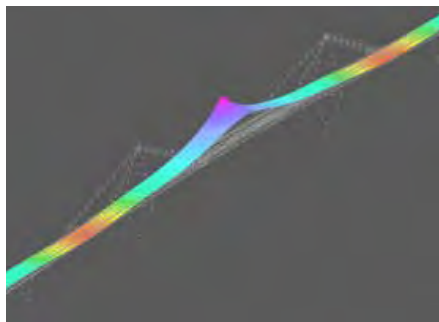


Figure 5: Influence surfaces for individual component members are generated by analyzing the effect of moving loads at various positions on the structure.

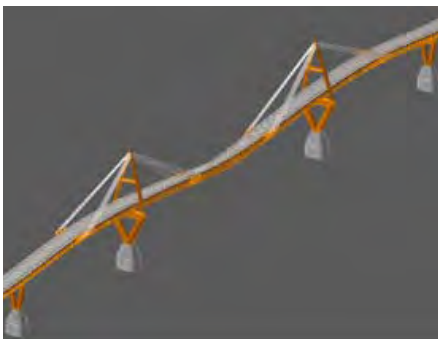


Figure 6: The model shows the bridge deformation due to placing the movable load at the position where it has the most significant effect.



Figure 7: One of more than 130 launch stages analyzed in developing the construction plan.



Figure 8: The cables are stressed in one step, but do not at that point take up the camber in the span adjacent to the main span.

The lifting span splice requires geometric compatibility of the truss ends (see Figure 9). This is achieved by loading the backspan through placing deck panels from the abutment to Pier 4. The design takes into account the construction demands including forces, deflections and rotations from the stages before.



Figure 9: The lifting span operation results in a load balance that brings the bridge structure close to its final constructed profile.

Unique Articulation

Two separate models were created to represent the different articulation scenarios depending on the nature of horizontal load effects. The bridge is fixed transversely at the piers and abutments. The continuous superstructure requires both flexibility for movements and fixity for load sharing of longitudinal loads. This contradiction has been resolved by the use of LUDs that release temperature restraining effects but engage the piers for external load effects such as wind and braking loads.

The master-slave joint feature of the software was used to model the articulation. The use of master-slave joints provides the option to couple or uncouple any of the six degrees of freedom to model various articulation conditions. In the end the bridge is fixed longitudinally for temperature load effects only at one main pier. The use of LUDs has enabled a seamless deck for the entire length of the bridge.

Erection Analysis

For the Deh Cho Bridge the following erection stages have been incorporated into the design:

- Launching 1,621-ft-long truss approaches from each abutment
- Installation of A-pylons and cables
- One-step stressing of all cables simultaneously by lowering truss at Pier 4
- Deck panel installation up to Pier 4
- Installation of 187-ft-long lifting span
- Deck panel installation in the main span
- Activation of composite action
- Casting curb and installation of railing
- Installation of waterproofing and wearing surface

A staged analysis for the launch was performed. The effect of camber was included in the analysis using a temperature load case. This method has the advantage of being able to turn camber off when the truss is moved ahead and connected to the supports in the new location. About 130 launch stages were analysed and summarized in demand envelopes. A typical stage is shown in Figure 7.

After erection of the A-pylon is completed, the truss is jacked up at Pier 4 to facilitate installation of the cables. Thereafter, the truss is lowered to its final position stressing all cables simultaneously, as shown in Figure 8.

Conclusion

The Deh Cho Bridge redesign is a unique example of an engineering assignment that involved a complex long-span bridge on a highly accelerated design schedule with considerable technical, project management and quality reviews. Rigorous analysis was conducted for cable tuning and camber, live load and other transitory loads. In addition, the staged analysis was conducted for the construction scheme. This investigation consisted of truss launching, cable stressing and a lifting span operation.

The principles of lightweight design were applied to value engineer the bridge. The redesign significantly simplified and improved the constructability of the bridge in addition to achieving an estimated 25% savings in structural steel. One of the major innovative features of the design is a continuous superstructure over the entire length of the bridge, making it the longest jointless bridge, from abutment to abutment, in North America. The submission of the issued for construction drawings earlier this year has enabled this project to move forward toward an anticipated completion in November 2011.

MSC

Owner

Government of Northwest Territories

Territorial Advisors

BPTC-DNW, Edmonton, Alberta, Canada (AISC Member)
T.Y. Lin International, San Francisco, California (AISC Member)

Quality Assurance

Sargent & Associates Ltd., Victoria, British Columbia

Engineer of Record

Infinity Engineering Group Ltd., North Vancouver, British Columbia, Canada (AISC Member)

Peer Reviewer

URS Corporation, Tampa, Fla. (AISC Member)

Steel Fabricator

Canam Steel Corporation, St. Gedeon de Beauce, Quebec and Point of Rocks, Md. (AISC and NSBA Member)

Structural Analysis Software

Larsa 4D

An Analytical Monitoring Tool for Bridge Construction

BY JASON STITH, BRIAN PETRUZZI, HYEONG JUN KIM, PH.D., TODD HELWIG, P.E., PH.D., ERIC WILLIAMSON, P.E., PH.D., KARL FRANK, P.E., PH.D., AND MICHAEL ENGELHARDT, P.E., PH.D.

Introducing a university-developed, robust, user-friendly finite element program for I-girder bridges during construction.

MANY BRIDGE ENGINEERS often put their primary focus on the behavior of bridges under maximum design loads in the final configuration. The current codes bear this out by devoting the vast majority of pages to the analysis and design of bridges in their final state. While assessing the strength and performance of bridges under service and ultimate loads is clearly important, the stage in a bridge's life that often has the smallest factors of safety is during construction when little if any bracing may be present. Because of the limited amount of bracing and uncertain support conditions, the construction condition is often the critical stage for system stability. Additionally, during construction, the behavior is controlled by the non-composite section that is usually proportioned for composite action in the finished bridge.

The issue becomes more prevalent as engineers use smaller top flanges in singly-symmetric girders. There have been multiple cases of I-girder bridges that have collapsed during construction including failures in Illinois, Colorado, and Tennessee. These catastrophic failures highlight the need to ensure stability during early construction stages when the final bracing is not present or fully effective.

Jason Stith is a Ph.D. candidate, Brian Petruzzi is a graduate research assistant, Hyeong Jun Kim is a postdoctoral researcher, Todd Helwig and Eric Williamson are associate professors, and Michael Engelhardt is the Dewitt C. Greer Centennial Professor in Transportation Engineering, all at the University of Texas at Austin. Karl Frank is the chief engineer for Hirschfeld Industries, Austin, Texas.

reported serviceability failures that occur when girder deflections vary significantly from predicted values that render the final bridge geometry out-of-tolerance. Such a case occurred in Wichita Falls, Texas, where a 2D grillage model failed to predict the excessive torsional flexibility of the curved bridge. The resulting cross-sectional geometry did not meet the roadway requirements and required a costly retrofit.

A solution for many of these problems is to develop the necessary limit states for construction and to analyze the bridge at each stage of the construction process. The issue is complicated in bridges with skewed supports and/or horizontally curved geometry where traditional 2D grillage models may not be appropriate for fully capturing the behavior of the system. Thus, it is desirable to perform a 3D finite element analysis (FEA) of such bridge systems at each stage of construction.

A User-Friendly Solution

UT Bridge is a 3D finite element program capable of performing a linear elastic analysis during each of the girder erection stages and the placement of the concrete bridge deck. An elastic analysis is suitable during construction because typical design and construction practices reasonably limit girder yielding during this early stage in a bridge's life. For the concrete deck placement, a linear incremental analysis was developed that is capable of accounting for the time-dependent nature of the concrete strength and the variation in the composite behavior as the concrete cures. Additionally, an eigenvalue buckling analysis can be performed to provide an indication of the global stability of the system at each of these critical stages and deter-

mine its critical buckling capacity. An example of that type of analysis is shown on the last page of this article (as Figure 8).

The central philosophy of the program is to provide a tool that allows engineers to quickly and accurately develop a 3D finite element model from the information readily available in the bridge plans. Basic features of UT Bridge include allowances for self-weight, wind loading, point loads, and temporary supports. The latter two features can be used to design erection plans accounting for the necessity and placement of shore towers or holding crane configurations (complete with crane loads).

Geometric features of the program include both straight and curved bridges, skewed substructure supports, any number of girders, and any number of spans. The user has three meshing options: coarse, normal, or fine. The default mesh density is the normal mesh and is suitable for most bridge geometries. Aside from selecting the mesh density, the entire finite element mesh is automatically generated by the program after the engineer defines the bridge layout using basic information commonly found on bridge plans. Therefore, extensive understanding of finite element modeling techniques on the part of the user is not required. Results from field measurements and other commercially available software packages have been used to validate the accuracy of the program.

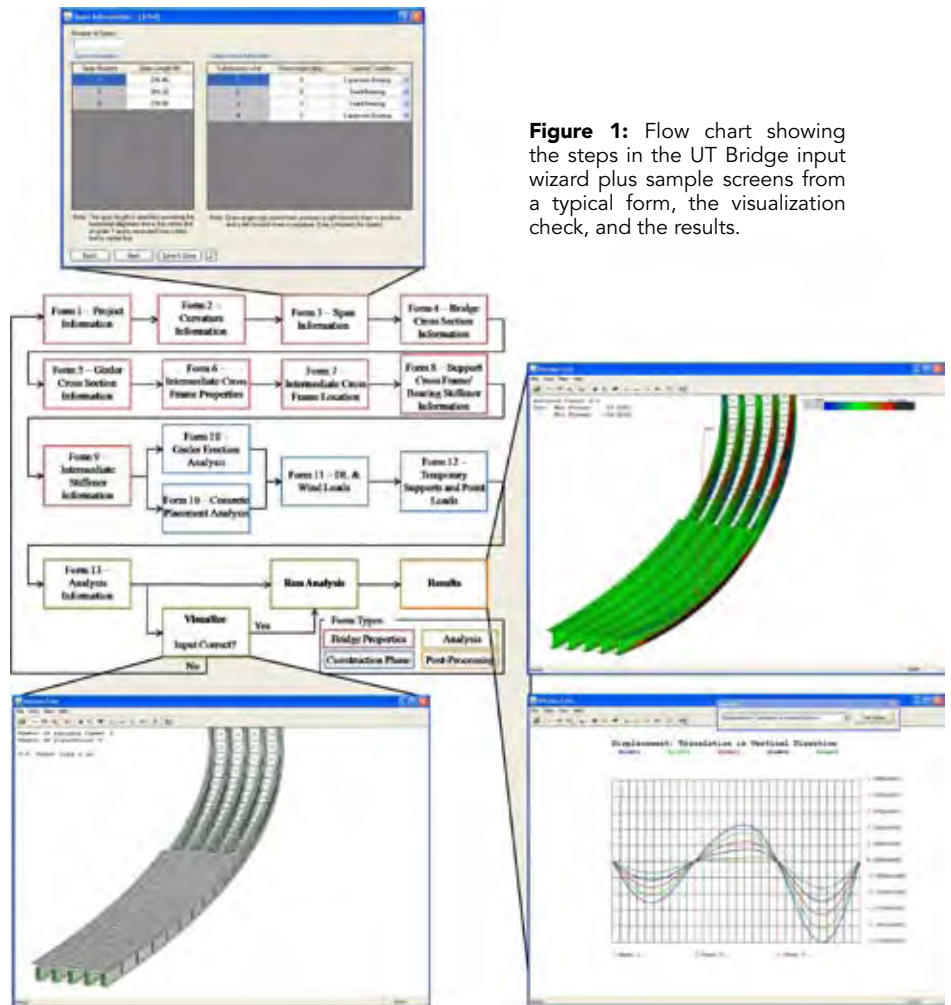


Figure 1: Flow chart showing the steps in the UT Bridge input wizard plus sample screens from a typical form, the visualization check, and the results.

Input Forms

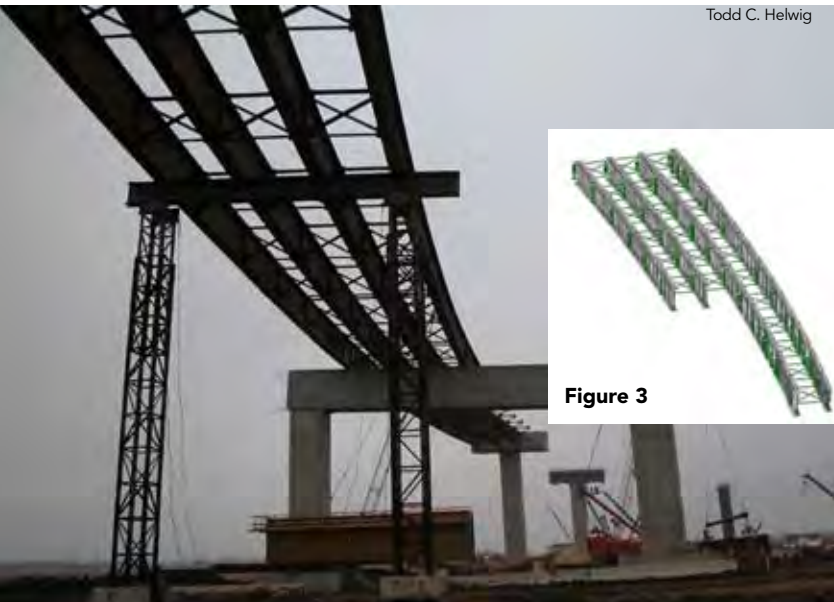
The welcome panel of UT Bridge prompts the user to begin an input wizard that consists of a series of 14 input forms. Figure 1 is a flow chart of the input wizard and a set of UT Bridge screen shots.

The first nine forms define the bridge properties, the next three define the construction analysis cases, and the last two allow the user to define the kinds of analyses to perform. The bridge property forms include all the geometric dimensions of the bridge necessary to define and develop the 3D model. They include information regarding span length, skew angle of substructure, cross-sectional dimensions, cross frame spacing, stiffener spacing, and other information found in a typical set of bridge plans. The input forms include help screens as well as preview features that an engineer can use to make sure that the desired bridge geometry is being correctly defined.

One of the most powerful features of UT Bridge is its ability to easily analyze a full bridge erection sequence. The program allows for the full bridge to be input once and then each step in the erection sequence to be ana

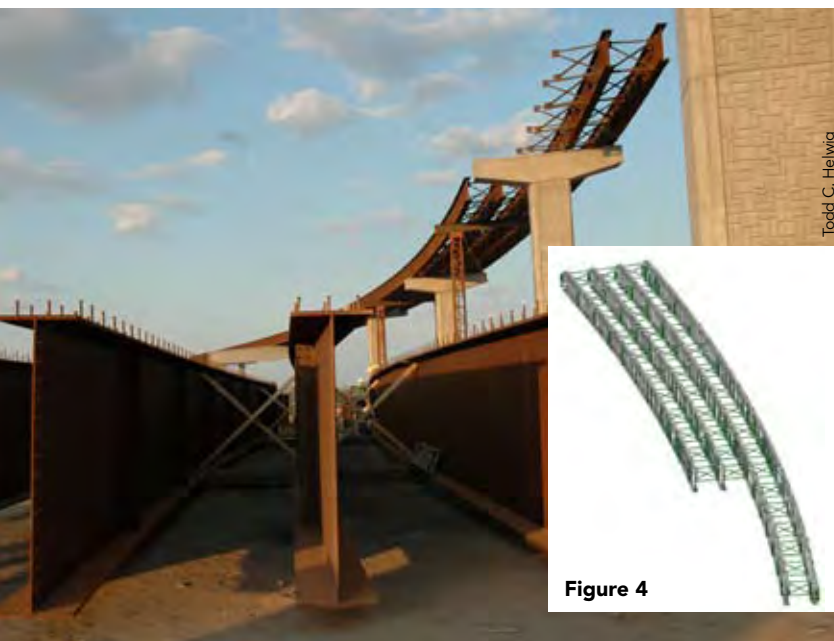


Figure 2: Photo and model for one step in the erection sequence.



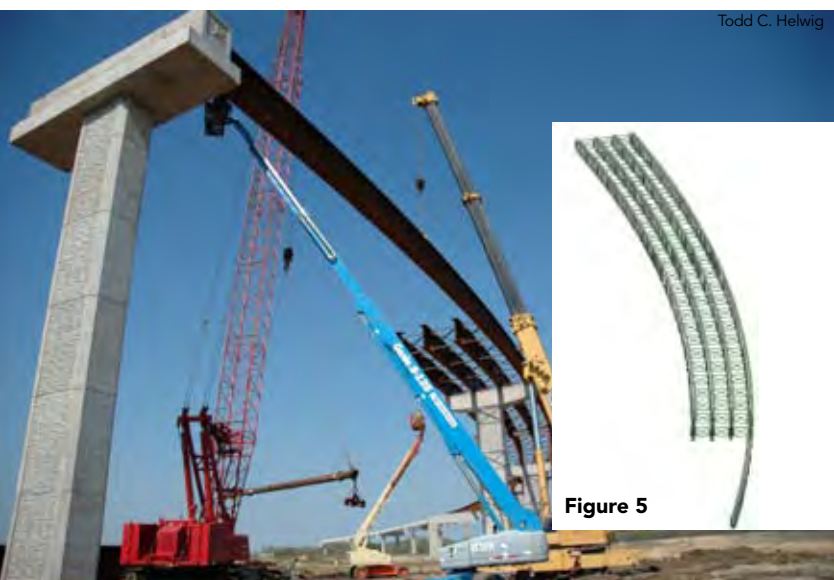
Todd C. Helwig

Figure 3



Todd C. Helwig

Figure 4



Todd C. Helwig

Figure 5

lyzed individually. The user defines which portions of the bridge (girder number and length) are erected during each lift, and the sequence becomes an analysis case. For each analysis case the program determines deflections, stresses, and rotations of each girder. The bridge model is assumed to be erected from one end of the bridge toward the other. This process can be completed ahead station or back station. Thus, a bridge built from each end and completed with a central drop-in section cannot be explicitly modeled, though it can be accurately approximated through various modeling techniques.

The program treats each set of lifted girders as an analysis case. Each analysis case can be a single girder or multiple girders depending on the lifting sequence used by the erector. Typically, the first girder lifted at a given cross section will be critical for stability design as the unbraced length is maximized for the bridge. Subsequent intermediate construction phases may be less critical and the analysis can be set up—or the engineer can choose—to erect several segments in a given stage to efficiently skip to the next potentially critical stage. This flexibility provides the erection engineer with options previously unavailable by current bridge analysis software. Figures 2 through 7 depict a bridge erection sequence with the associated UT Bridge model.

The other option for analysis is the ability to model the concrete deck placement. Concrete is normally placed either continuously or in positive moment regions first then negative moment regions. The user can specify the sequence of the deck placement and analyze the state of stress for each stage of the concrete placement. Although many designers do not consider the stiffening effect of previously placed concrete, the program has the ability to reflect the contributions of previously placed concrete. This requires that the early-age concrete be modeled in a time-dependent nature. Thus, a linear incremental analysis technique is used where the loads in the present analysis case are applied to the current system stiffness. The increment of displacement and stresses is then summed with all previous analysis cases to obtain the current state of displacement or stress.

The modeling of the interaction between the shear studs and the early-age concrete has not been studied extensively; however a relatively detailed experimental study was conducted at the University of Texas in 2002. The study was conducted with Class-S type concrete, which is commonly used in Texas bridge decks. The study produced a model to predict the interaction between the modulus of elasticity of the concrete and the stiffness of the shear studs. The method has been incorporated directly into UT Bridge so that an engineer can accurately estimate the contribution of previously placed concrete based upon the time between stages in the deck placement. If the user does not specify a time between concrete deck placement stages, the stiffening effects of the concrete will not be modeled.

Within the construction analysis, the dead load can be factored and a wind load applied. Two other critically important features available are the inclusion of point loads at any location on the girder and temporary supports under the girder at any point along the length of the bridge.

These can be specified for each stage of the analysis, allowing the engineer to optimize the location of holding cranes and false work, such as shore towers, that critically alter the stability of the partially constructed bridge system. The last two input forms allow the user to define the kinds of analysis to perform.

UT Bridge includes 3D graphics displayed in a window named UT Viewer. While the primary purpose of UT Viewer is for post-processing the results from the structural analysis, the feature also provides the engineer an invaluable tool to ensure the bridge intended to be modeled was properly input and key structural elements are located as indicated on the bridge plans. A visualization option is provided in the input forms that quickly develops the bridge geometry, but does not actually perform an analysis. This allows for a check of the input prior to the analysis.

Results

The displacement-based finite element analysis approach used in this program results in the numeric approximation of the nodal displacements, which are the primary variables. The calculation of the nodal stresses is a derived or secondary variable that must be calculated after the program calculates the displacements. This final step in the finite element analysis is referred to as post-processing.

Results from UT Bridge are displayed in UT Viewer, which was created to help the user easily view and interpolate the results from a set of analytical cases. After loading the results file, the user can view the bridge geometry, the deformed shape from the scaled displacements, and a contour plot of the stresses. Additionally, UT Viewer can display numerous 2D linear plots (XY plots) showing the displacements, rotations, and stresses at tenth points along the length of the bridge for each girder.

The information used to generate the XY plots also is available in a tabular form, which allows the user to copy and paste the information to other programs such as spreadsheets for further analysis. Data such as the tenth point deflections for each girder provide information that can be used to determine necessary cambering requirements for individual girders. This feature can be extremely valuable, particularly in systems with significant degrees of horizontal curvature and/or skewed supports.

Additionally, cross frame forces and reactions for each of the members are given in tabular form for exporting. The cross frame diagonals are assumed to be tension-only members and thus one diagonal will report zero force. The reactions for both permanent and temporary supports are given.

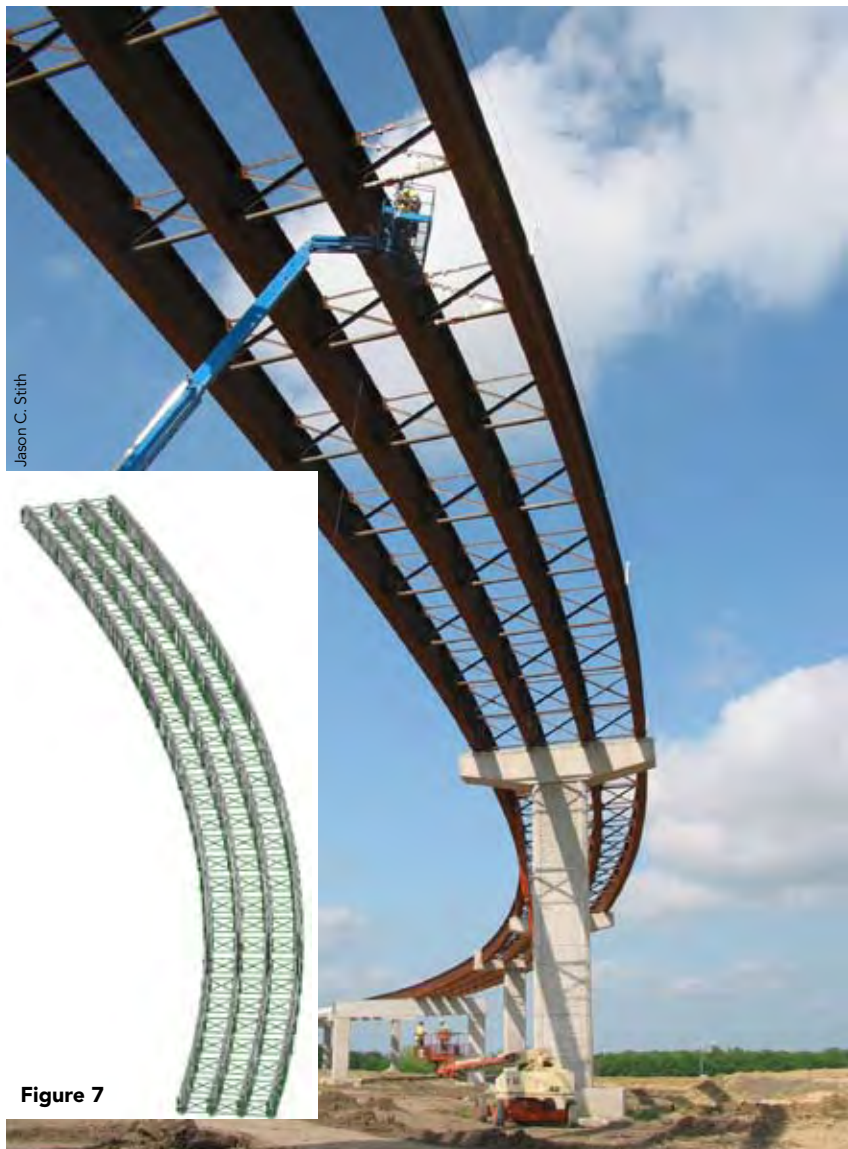
The program has been verified throughout the development at element level, girder level, and system level. A set of actual bridges were used to demonstrate the verification comparing field data, commercially available grillage programs, and 3D finite element models in ANSYS.

The UT Bridge software provides a relatively fast interface for creating 3D models and analyzing critical construction stages. The availability of UT Bridge to engineers provides a powerful tool for the evaluation of the performance of plate girder bridges during construction that more rea-

Todd C. Helwig



Figure 6



Jason C. Stith

Figure 7



sonably model the existing conditions compared to many existing programs. **MSC**

The authors would like to acknowledge the Texas Department of Transportation (TXDOT) for its technical and financial support of this project.

UT Lift, another bridge construction-related program developed at the University of Texas at Austin, was the subject of a 2009 World Steel Bridge Symposium presentation. The symposium paper is available as a free download from the AISC website at <http://bit.ly/dpP7Z5>.

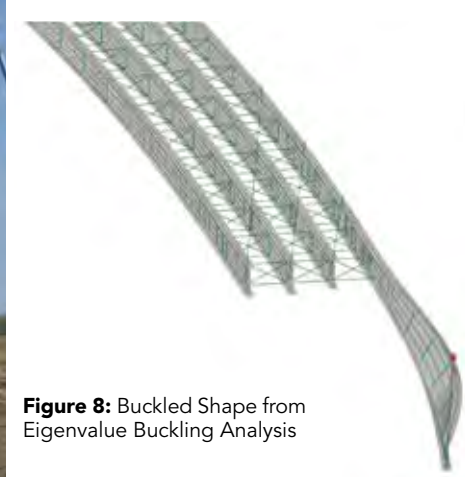


Figure 8: Buckled Shape from Eigenvalue Buckling Analysis

Jason C. Stith

The Power Factor

The speed and data storage capacity of modern computers has made it possible for engineers to conduct sophisticated analyses of complex structural systems on personal computers or even portable laptop computers. The current significant impediment for bridge engineers in conducting a robust analysis of bridge systems is no longer related to computing power or technical capabilities of the software, but is instead generally in the user interface for computer programs to conduct these analyses. A 3D finite element analysis (FEA) has historically required expensive software and significant time to develop the models.

Although suitable programs are available, the time demand for a user to become familiar with many commercially available 3D FEA programs also impedes widespread use of these robust analytical tools. The lack of intuitive analysis programs applicable for modeling the construction sequence, which often is the most critical stage in the life of a bridge, was the driving force for the development of the software UT Bridge.

The software was developed at the University of Texas at Austin with support from the Texas Department of Transportation. UT Bridge is available as a free download at <http://fsel.engr.utexas.edu/software/>. Sample files and a training module are included in the downloaded file.

Colleges and universities are meeting similar challenges with a variety of steel solutions.

Getting Across Campus

BY JOSEPH E. SHIELDS, P.E., LEED AP

Two new bridges connect the Knapp Center for Biomedical Discovery to other buildings on the University of Chicago campus. An eccentrically located narrow braced frame provides support at one end of this 90-ft bridge, made more challenging by a significant difference in the weight of the cladding materials on the sides of the bridge. Photos by the author except as noted.



PEDESTRIAN BRIDGES on college and university campuses often play a symbolic role in addition to their physical role in providing a valuable connection between two points. Many schools have been making great strides to increase the inter-disciplinary nature of their institutions and in doing so have been taking extra effort to bridge both the physical and organizational separations that exist on campus.

A perfect example is the Knapp Center for Biomedical Discovery, at the University of Chicago, which includes two new pedestrian bridges on its Hyde Park campus on Chicago's south side. The longer of the two is a 90-ft span connecting the Knapp Center at its third floor to the nearby Gordon Center. The second is a 35-ft span to the Donnelley Biological Sciences Learning Center.

The 90-ft pedestrian bridge is elevated three floors above the sidewalk below and is supported by the Knapp Center on one end. On the opposite end the bridge is supported by a narrow braced frame, less than 4-ft wide, positioned eccentric to the bridge. This peculiar means of vertical support was driven both by the architect's desire to make the supports look as slender as possible and a need to avoid existing underground chiller and steam tunnels. Additionally, one face of the bridge is covered in limestone while the opposite face is a relatively lightweight glass curtain wall. This dramatic difference in cladding materials coupled with the eccentric support condition proved to be a particularly challenging aspect to the bridge's design. The end result is something that could be made possible only through the use of a steel frame structure.

Just a few miles north, on the campus of Northwestern University in Evanston, Ill., two steel vierendeel trusses that support a two-story office wing—and which span 99 ft—are the main structural feature in the new Richard and Barbara Silverman Hall for Molecular Therapeutics and Diagnostics. In addition to its impressive span, the office wing cantilevers 14 ft beyond the edge of the truss, providing the faculty offices column-free space and beautiful unobstructed views of the Northwestern campus and adjacent Lake Michigan.

Supported on built-up cruciform columns, the trusses are fabricated from heavy W36 and W40 wide-flange sections. Vertical truss members are attached to the continuous top and bottom chords using full penetration welds. The truss chords required vertical stiffeners and web doubler plates to achieve the extreme moments at these connections. The design team also provided the contractor the option of using a plate girder to avoid the use of stiffeners and doubler plates. Based on steel availability and cost determined by the steel fabricator and detailer, it was more cost effective to use the stiffened wide flange as opposed to the plate girder option. Rather than clad the entire truss, a portion of the vertical elements



Above: A 14-ft cantilever beyond the truss structure provides additional office space on this bridge on the campus of Northwestern University.

Below: Two vierendeel trusses support the 99-ft span of the new Richard and Barbara Silverman Hall for Molecular Therapeutics and Diagnostics. Photo (c) Mark Ballogg Photography, courtesy of ZGF.

on one side is painted and exposed. The beauty of the underlying structure is shown in plain sight and if you pay careful attention to the flange thickness of the exposed members you can observe the variation in force as it flows through the truss.

Going West

One of the newest and most featured building additions to the College of DuPage, in the Chicago suburb of Glen Ellyn, Ill., has been integrated into the existing campus using a 96-ft clear-span pedestrian bridge. The bridge links the new Health Careers and Natural Sciences building to the existing student union. It consists



Joseph E. Shields, P.E., LEED AP, is a senior engineer in the Chicago office of Thornton Tomasetti. He can be reached at js Shields@thornton-tomasetti.com.



Architecturally exposed HSS sections form the verticals and diagonals of the trusses on this bridge linking the Health Careers and Natural Sciences building to the student union at the College of DuPage.

of two traditional Warren type trusses supported at each end on steel columns. Truss verticals and diagonals are composed of architecturally exposed HSS sections. An AESS criterion was specified for the truss elements and connections to ensure a finished look for the exposed portions.

Our specifications required members indicated as AESS to be in compliance with the AISC *Code of Standard Practice for Steel Buildings and Bridges*, Chapter 10. In addition we have unique specification language regarding the fabrication, connection, surface preparation, and finishing of AESS members to satisfy the architect's desired look.

The pedestrian bridge began as an alternate, but thanks to a favorable bidding environment, it was able to become a reality. It is clad in alternating clear and translucent glass panels that match the exterior of the adjacent building and provide a distinctive addition and contemporary look to the growing College of DuPage campus.

The many pedestrian bridges on college campuses, although sometimes overlooked among the buildings themselves, can prove to be a visually dramatic and functional addition. Each of these bridges has become a signature aspect of the buildings to which it

connects, and all have improved the overall connectivity of the schools themselves, providing an easier means of transporting students and faculty across campus, but also providing a more unified campus environment overall. From the structural engineer's perspective, the pedestrian bridge is an opportunity to provide design services for elements such as long spans and trusses that may not be encountered in typical building construction. MSC

Knapp Center for Biomedical Discovery, University of Chicago

Architect

Zimmer, Gunsul, Fransca Architects LLP, Los Angeles

Structural Engineer

Thornton Tomasetti, Inc., Chicago (AISC Member)

Steel Fabricator

Zalk Josephs Fabricators, LLC, Stoughton, Wis. (AISC Member)

General Contractor

Turner Construction, Chicago

Richard and Barbara Silverman Hall for Molecular Therapeutics and Diagnostics, Northwestern University

Architect

Zimmer, Gunsul, Fransca Architects LLP, Los Angeles

Structural Engineer

Thornton Tomasetti, Inc., Chicago (AISC Member)

Steel Detailer

Waukegan Steel Sales, Inc., Waukegan, Ill. (AISC Member)

Steel Erector

Area Erectors, Wheeling, Ill. (IMPACT and TAUC Member)

General Contractor

Turner Construction, Chicago

Health Careers and Natural Sciences Building, College of Dupage

Architect

Hellmuth, Obata + Kassabaum (HOK), Inc., Chicago

Structural Engineer

Thornton Tomasetti, Inc., Chicago (AISC Member)

Steel Fabricator and Detailer

LeJeune Steel Co., Minneapolis (AISC Member)


General Contractor

Gilbane Building Co., Chicago

Featuring asymmetry in two major planes, Michigan's first cable-stayed bridge was a challenge in both design and construction.

On a *Beautiful* **Tilt**

BY ROBERT B. ANDERSON, P.E.,
MIKE GUTER, P.E., AND VICTOR JUDNIC, P.E.



The new Mexicantown Bagley Street Pedestrian Bridge in Detroit crosses I-75 and I-96 and is Michigan's first cable-stayed bridge.

DETROIT'S NEW MEXICANTOWN Bagley Street Pedestrian Bridge is the first cable-stayed bridge in the state and part of Michigan's \$230 million I-75 Gateway Project. The two-span, cable stayed structure crosses 10 ramps and roadways, including both I-75 and I-96, and provides a vital link between the east and west sides of Detroit's Mexicantown community.

The total bridge length is 417 ft, with a main span of 276 ft and a back span of 141 ft. The forestays are arranged in a fan configuration and are inclined in both the longitudinal and transverse directions. The bridge features a unique asymmetrical design, with a selected look of a single cable plane. A single 155-ft-tall inclined pylon provides the upper support for the cables, which form an eccentric plane and are anchored at the lower end to a tapered, trapezoidal, single-cell steel box girder.

The back span balances the forces imposed by the forestays and anchors into a deadman/abutment. The welded steel, trapezoidal box girder carries the variable-width deck slab. The project incorporates

five tuned mass dampers to control vibration of the bridge superstructure. Each portion of the project, including abutments, entry plazas, barriers, and fencing employs architectural finishes with three-dimensional variations, and is therefore highly stylized aesthetically.

The bridge lies on a tangent horizontal alignment. The western span expands from 15 ft, 3 in. to 21 ft, 6 in. while the shorter eastern span widens even more dramatically, from 21 ft, 6 in. to 34 ft. The pedestrian walkway entrance and exit grades of the vertical profile are at 5% grades and are connected by a 200-ft crest vertical curve whose midpoint is located near the pylon. The minimum vertical clearance to the closest underlying roadway is 16 ft, 10³/₈ in. at the eastern abutment.

The structural system—a single-cell box girder superstructure—is supported at the westerly forespan by stay cables anchored eccentrically to the girder shear center at the northern girder web. The eastern back span is self-supporting and also transmits compression forces introduced by the westerly forestays to the east abutment.

The eccentric cable loading on the single box girder system produces torsion and lateral thrust in the girder and this is resisted by upward, downward, and lateral bearings at the west abutment and tension linkages and vertical and lateral bearings at the pylon. This figure shows that both vertical and lateral bearings are used to resist torsion. The pylon linkage and bearing system also allows translation produced mostly by thermal affects along the longitudinal axis of the bridge.

The concrete and steel pylon is eccentric in two directions and also tapers in two directions from its base to its top. The foundation, at the base of the pylon, resists gravity loads primarily by a cluster of piles located at the line of action of the pylon. An extension of the foundation to the north helps to resist overturning loads created primarily by wind and live load effects.

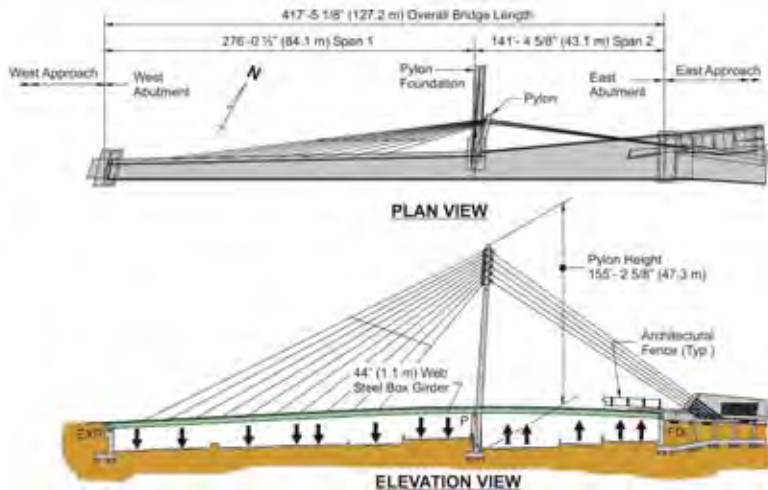
Construction Activities and Scheduling

This bridge required a detailed erection manual and geometric control plan prepared by a specialty erection engineer. The erection manual outlined 62 individual stages for completing the bridge and closely followed the proposed erection plan conceptualized by the design engineer and included in the contract documents.

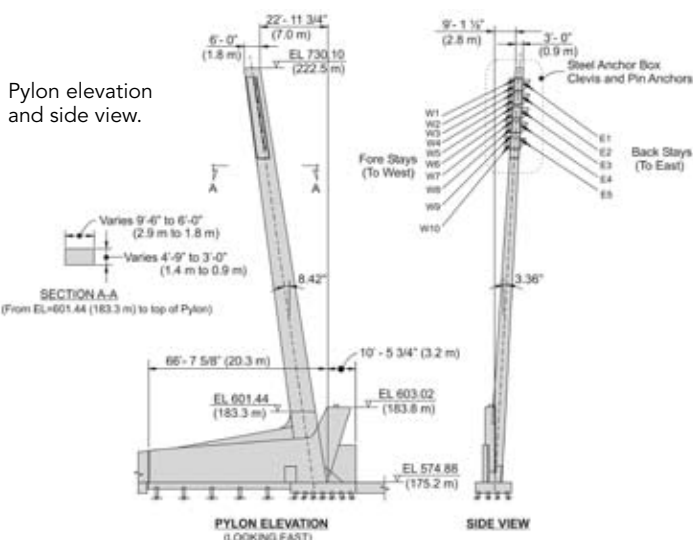
To ensure that survey discrepancies would be minimized and resolved quickly, the project team agreed to coordinate all surveys. The erection engineer, as part of the erection manual and ongoing computations, provided target coordinates and elevations for key points and elevations, including at the pylon stay housing, at temporary shoring, at box girder splices, along the box girder deck and at all stay cable connection points.

The contractor and the owner/engineer closely monitored the geometry throughout construction. In one instance, the temporary guys were adjusted to correct the location of the pylon stem; however giving credit to the accuracy of the erection engineer's analysis, the geometry largely agreed with the predictions.

The steel box girder erection scheme required three falsework towers to support the west span before the stay cables were installed. The contract documents included camber values to account for these three temporary supports. Two additional falsework towers were provided at each side of the pylon to support the girder prior to the deck pour engaging the vertical and lateral bearings and link plates at that location. The contractor opted to complete the top of the pylon strut after placement of the steel



The plan and elevation view show the bridge's general layout, including the pylon's eccentricity in two directions.

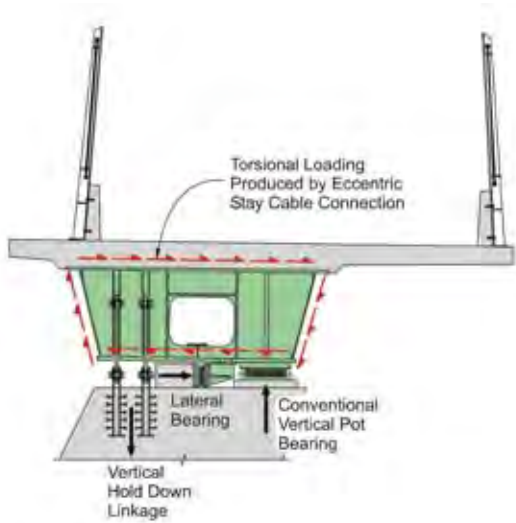


box girder to mitigate tolerance and fit-up requirements of the girder itself and the many support elements.

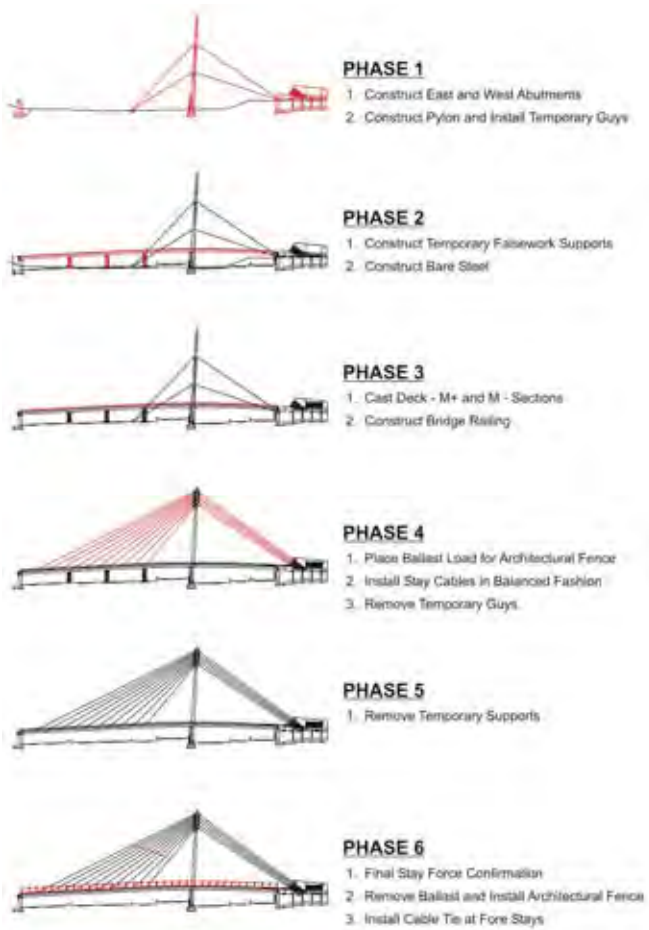
The first major step in the bridge's construction was to build the abutments and the pylon. To help maintain alignment and provide support during construction and prior to installation of the stay cables and pylon post-tensioning, the pylon was temporarily guyed with four guys at two vertical levels. At each level, guys extended transverse and longitudinal to the bridge axis to maintain pylon stability and provide support in all directions.

Robert B. Anderson, P.E., is a senior structural engineer for URS Corporation, Tampa, Fla., and has been involved in the planning, design and construction of bridges for more than 21 years. Bob's experience includes the design of five major cable-stayed bridges, several major freeway-to-freeway interchanges, as well as numerous water crossing structures. Mike Guter, P.E., is a project manager for URS Corporation in Grand Rapids, Mich. He has worked on a variety of transportation projects since beginning his career in 1993, including roles in both construction and design. Victor Judnic, P.E., is a senior construction engineer for the Michigan Department of Transportation. His experience includes the design and construction of harbors, roads and bridges over the past 21 years.





Layout of the pylon linkage and bearing system, showing hold down linkage as well as vertical and lateral bearing areas.



Major construction phases of the Bagley Street Bridge.

Construction started at the east abutment, which serves as the bridge abutment; an earth anchor wall for five stay cables anchoring the front span of the bridge; and an architectural plaza that transitions from the pedestrian bridge to a much larger non-structural plaza area. This abutment also was used as the temporary anchor point for the east temporary pylon guys.

Additionally the east abutment provided the fixity for the steel tub girder, with a diaphragm cast integrally with the girder. The eastern end of the girder was temporarily supported on bearings to allow for beam rotation during the deck pour. The temporary bearings ultimately were encapsulated in concrete and the integral abutment connection was made complete.

The back span is fully supported by the east abutment and the pylon strut. The east abutment earth anchor wall is constructed on a 6-ft by 6-ft, 11-in. concrete grade beam that was integrally tied to the remainder of the abutment with steel reinforcement. The stay cables are anchored with steel forgings connected to post-tensioned anchor rods that include an end plate poured into the grade beam. A structural and architectural wall extends up from the grade beam, supporting, hiding and protecting the anchor rods. This wall has aesthetic treatments including bush-hammered and board-formed surfaces.

The west abutment was the next substructure element to be constructed. A more conventional abutment, it includes three pot bearings supporting the steel box girder vertically (both upward and downward to prevent torsional rotation) and transversely.

Accommodating Foot Traffic

Some pedestrian bridges have shown sensitivity to the dynamic affects of foot traffic. The design engineer worked in conjunction with a specialty dynamics consultant who specified and detailed a five-component tuned mass damper system that was included as part of the contract documents. The installation of the tuned mass damper system was undertaken after girder erection and prior to the deck placement. Four of the dampers resolve vertical movement and a single damper resolves lateral movement. When the bridge was nearly complete, the damper system designer conducted a series of dynamic tests to establish the spring fabrication parameters. After spring fabrication and installation, the damper system characteristics were fine tuned to correspond with the measured dynamic response of the bridge and to ensure their effectiveness.

On to the Superstructure

The east abutment earth anchor wall plate, pylon stay cable housing, and steel box girders are shop fabricated steel components. The earth anchor plate forms a base for the five east stay cable anchor blocks. This assembly was cast into the concrete earth anchor wall. Post-tensioned bars extend from the face of this plate into a concrete beam that sits underneath the earth anchor wall.

The pylon stay cable housing is 30 ft, 6 in. in height and forms the northern half of the top pylon stem. The stay housing includes five 2½-in.-thick plates with two pinholes on the west side and one pinhole on the south side for connection to the clevis-type stay cable anchorages. The placement of the stay housing was controlled by levelling nuts on 18, 1½-in. anchor bolts poured into the pylon stem.

The box girder remains a constant width from the west abutment to just west of the pylon, at which point it begins to widen to its largest width at the east abutment. The top flange of the box girder also varies from being solid across the top, in areas of high torsion, to being split into two flanges on top of each web. In areas where the top flange spanned from web to web, plates were added to provide bending strength to support the concrete deck placement. In addition, tuned mass dampers (see sidebar) installed between the west abutment and the pylon required top flange openings to be covered with plates after installation.

Phase 2 (see construction phase diagram) shows the next major construction step involving the assembly of the steel box girder on both false-

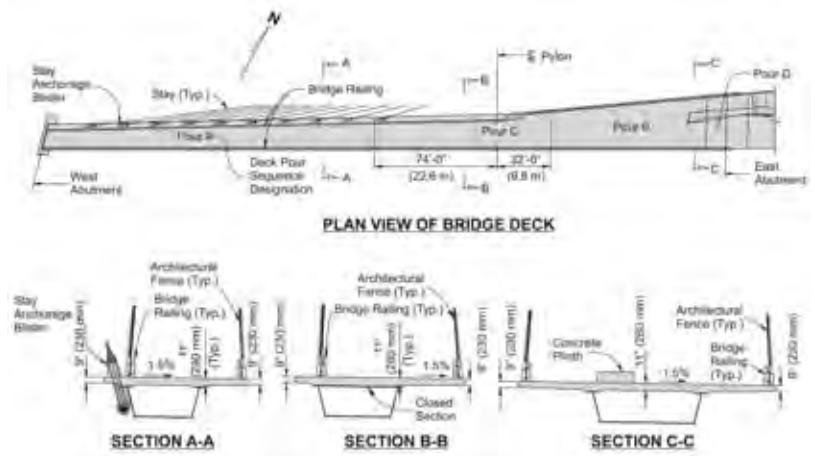
work and permanent supports. Temporary support elevations were determined as part of the erection manual. Top of beam elevations were determined and checked against the anticipated elevations (which included the girder camber accounting for later deflections), and then screed rail elevations were established and the deck slab was cast in typical fashion. Because fencing fabrication and installation took longer than expected, the contractor elected to temporarily ballast the bridge with a uniform load consisting of wide-flange steel beams from their stockpile.

The most complex part of the deck slab construction was developing a unique deck forming system to construct the large overhangs (see diagram, Phase 3). The contractor devised a formwork system suspended beneath the bridge and hung from the box girder flanges. HP12x53 sections were the primary members spanning from flange to flange and overhanging each side from which forms were supported. The hangers counteracted torsional forces of the asymmetrical deck overhang by using steel plates as beams extending across the top of the box girder. Uplift forces were counteracted at the center of the beam with a welded tie-down at the solid top flange and cable tie-down at the open flange sections of the box girder. The overhang forming was set approximately 1/2-in. high to account for the anticipated deflections of the overhang during the deck pour. To maintain the freeway opening date of July 4, 2009, the deck slab was poured during February 2009, an unusual occurrence this far north.

Phase 4 involved the installation and stressing of stays in a balanced fashion at both the west and east sides of the pylon. Each of the 15 stay ends (10 in the forespan connected to girder and five connected to the east abutment back stay) had a targeted force. Some of the stays required only a single jacking operation within the erection manual sequence, while others required two jacking operations at different stages within the erection manual sequence. During the jacking operations and upon completion, the geometry of the system was verified. As the installation of the permanent stays progressed, the temporary guys were removed. Also, the stressing of the stays caused a decrease and eventual lift-off at the temporary falsework supports. At Stages 47, 53, 54, and 60 of the erection engineer's detailed construction sequence, the vertical pylon post-tensioning was installed and stressed in stages.

Working with the Stays

The stay cables consist of galvanized steel wire rope comprising structural wire (ASTM 586) with a hot-dipped galvanized Class A coating for the inner wires and Class C coating for the outer wires. One end of the cable at the pylon used a pin and clevis anchorage system. The forestays used a threaded spanner nut anchorage system at the girders. The back stays were anchored at the east abutment with a steel anchor block casting and shims that were tensioned with four anchor rods each embedded into the abutment mass. The clevises and other hardware were manufactured in a lost sand casting process (ASTM 148). The stay cable socket-to-strand connection was accomplished by splaying the wire rope and pouring molten zinc into a conical shaped space. The sockets are designed and attached to develop 110% of the breaking strength of the



Deck plan and cross sections. Note the variation in relative location and size of the steel box girder.



Bob Anderson, URS Corporation



The pylon stay cable housing in place with the lower two back stays attached.

The 30-ft, 6-in.-high steel pylon stay cable housing forms the northern half of the top pylon stem, shown here prior to placement with concrete formwork panels attached. Five 2 1/2-in.-thick plates have two pinholes on one side and one pinhole on the other for connecting the clevis-type stay cable anchorages.

The west abutment prior to setting the tub girder. Note the non-symmetrical support system, with hold down anchorage on the left and bearing on the right.



Mike Guter, URS Corporation



Mike Guter, URS Corporation

The end of the tub girder with welded studs attached, ready for placement on the west abutment.



Bob Anderson, URS Corporation

The completed west abutment.

cable. All sockets were proof tested to 55% of the breaking strength of the cables. The lengths of the cables were determined by survey following completion of the pylon and erection of the girder. Tolerance was provided in the threaded socket length to account for construction tolerance and temperature compensation.

Because galvanized wire rope is able to wick moisture within the cables, painting of the stay cables was included in the contract to prevent the ingress of water and corrosive elements. However painting subsequently was eliminated due to concerns about the long-term effects of locked moisture and oils on the coating system. Serrated nuts were added at the low cable anchorage at the west girder and weep holes to the anchor WT's attached to the girder webs to facilitate the draining of water from the cable bottoms.

The first step in field installation is to unwind the cables from wooden shipping spools. Because of their length weight, this can be an awkward operation and requires special attention to avoid unwinding the spools too fast. To protect the galvanized coating on the cables, they are laid out on a protected surface. The cables are then lifted by two cranes and attached at the pylon stay cable housing, then attached at the girder or abutment.

For the Bagley Street Bridge's western forestays, workers installed a threaded stressing rod into the anchor socket, along with a temporary extension rod, which allowed stressing by a single center-hole jack. Once the proper tension was achieved, a ring nut was spun tight.

At the east abutment, a stay cable anchorage block was positioned through four threaded anchor rods. These rods were stressed to a prescribed tension by four center-hole jacks bearing against nuts on the rods and the anchorage block. Once the tension was achieved, shims were installed between the stay cable anchorage block and the base of the abutment earth anchor wall. Final tensioning of the anchor rods, with the shims in place and preventing the cables from being further loaded, was done to a high load level to ensure the shims remain in compression.

Calibrated jacks were used to stress the cables. However, the stay cable supplier used a secondary "tensionometer" to monitor the stay cable tension in all the cables



The complex erection sequence required the use of three falsework towers, which supported the west span until the cable stays were attached.

after each was stressed. This device accepts inputs of cable density and length and has an accelerometer sensor that is able to measure the primary frequency of a cable. The cable is forced to vibrate by field personnel. With these vibration inputs, the tensionometer outputs a measured force obtained by classical equations that are programmed into the equipment.

Finishing Up

The bridge finishing works shown in Phase 6 include the final steps involved in the construction of the bridge. These included verification of cable forces and girder and pylon geometry; installation of the architectural fence; installation of a cable tie at the forestays to reduce stay cable vibrations; and final tuning of the tuned mass dampers.

Other tasks included in the bridge finishing works were:

- Removal of steel ballasting and construction of concrete barrier rail
- Sandblast finishing of the pylon, deck overhangs, and barrier rail
- Installation of modular expansion joint at the west abutment
- Concrete benches at the pylon and east abutment and decorative concrete treatments
- Completion of lightning grounding system
- Installation and aiming of decorative lighting
- Grouting of east abutment post-tensioned stay cable anchor rods
- Installation of architectural edge plates and fence mesh covering at east abutment

The Mexicantown Bagely Street Pedestrian Bridge opened May 5, 2010. It was part of a Cinco de Mayo festival organized by the Southwest Detroit Business Association and the Detroit Consulate of Mexico in salute of 200 years of Mexican independence.

A project of this magnitude relies on contributions from many

individuals; therefore, the authors also wish to acknowledge and give their sincere appreciation to Bob Jones and Josh Goldsworthy (Walter Toebe Construction), Dave Rogowski (Genesis Structures), Eric Morris and Ken Price (HNTB), Jerry Clodfelter (CBSI), Jorge Suarez (Michael Baker Corp.) and Peter Bugar (URS). **MSC**

Owner

Michigan Department of Transportation

Architect

Van Tine/Guthrie Studio of Architecture, Northville, Mich.

Design Engineer

HNTB Corporation, Chicago
(AISC Member)

Construction Inspection Engineer

URS Corporation, Grand Rapids, Mich., and Tampa, Fla.

Specialty Construction Inspection

Michael Baker Corporation, Pittsburgh

Steel Detailer

Tensor Engineering, Indian Harbour Beach, Fla. (AISC and NISD Member)

Steel Fabricator

Industrial Steel Construction, Gary, Ind. (AISC and NSBA Member)

Erection Engineering

Genesis Structures, Kansas City, Mo. (AISC Member)

General Contractor

Walter Toebe Construction, Wixom, Mich.

Structural Software

Lusas Bridge

Stay Cable System Supplier

CBSI, Houston



Real-Life Lessons

BY THOMAS L. KLEMENS, P.E.

Students who participate in the student steel bridge contest learn far more than structural analysis and design.

FEW THINGS ROUSE the enthusiasm of young civil engineers more than the prospect of designing and building a steel bridge, and the annual AISC/ASCE-sponsored student steel bridge competition offers a great opportunity for that. Each year thousands of engineering students from across North America form teams, strategize, design and build out their dreams in this high-level simulation of a real-world bridge construction project. In the process, their hands-on learning experiences range from interpreting detailed project specifications to designing, fabricating and constructing 20-ft-plus spans that have to stand up to real loads.

The competition began in 1987 when teams from three Michigan engineering schools met for the first steel bridge contest. The event was hosted by Lawrence Technological University, Southfield, Mich., with visiting teams from nearby Wayne State University, located in Detroit, and Michigan Technological University, from Houghton, in the state's Upper Peninsula. The event originated with Bob Shaw, who was then manager of college relations for the American Institute of Steel Construction.

Additional teams entered the following years, and in 1992 Michigan State University hosted the first national student steel bridge contest on its East Lansing, Mich., campus. Also that year, AISC officially took on sponsorship of the contest under its newly appointed director of AISC college relations, Fromy Rosenberg. Thirteen teams participated that year, and MSU's zero-deflection span was victorious.

Since then teams from across the nation have gathered every spring to pit their design and construction skills in a fresh challenge

guaranteed to spark the imagination and inspiration of civil and structural engineering students. Today the program is cosponsored by the American Society of Civil Engineers (ASCE) with the initial round of each year's competition based on ASCE's 18-conference organization. In 2010, the regional events included 192 teams, with 46 advancing to the finals held May 28–29 in West Lafayette, Ind., at Purdue University.

Watching the finalists compete in both the display and construction sessions, the value of the contest becomes quite clear: The challenge in the steel bridge contest very much reflects a real-world project scenario. Young engineers who participate learn key lessons that go far beyond standard class work. And in a field where experience counts, being on a college or university's steel bridge team is something worth noting.

The bridge requirements are revised each year. For 2010, the structure had to span a 13-ft, 6-in-wide river and an adjacent 5-ft floodway. The bridge piers were to be located on each end of the span, with only temporary supports permitted in the river or floodplain. Although a portion of the team could work as "barges" in the river, land access was limited to one bank, with strict limits on loads within the floodplain. The "owner" placed a premium on stiffness, light weight, and speed of construction. (For the complete project specifications, see Section 6 of the 2010 rules, which can be downloaded from the History and Results area at www.nssbc.info.)

Team members, as usual, had their hands full just wading through the project requirements, which itself is a lesson in the

Opposite page: The North Dakota State University team's bridge members were precisely designed and fabricated for quick and simple assembly. The mechanical joints along the various truss members do all the structural work; bolts in the web-like interstitial spaces provide stability and compliance.

reality of construction projects. But then came the question of how best to meet the challenge.

Many teams began early last summer to conceptualize their approach for this year's competition. Once the rules including the specific challenge were made public in August, the work—and the learning—began.

So, based on observations at the 2010 final round of competition, what are the lessons learned? Here are just a few.

Conception and Design

Each competing bridge must meet the specifications as described in the 38 pages of rules, which includes passing a 2,500-lb. load test. However, to be competitive, it also must be optimized for maximum strength at minimum weight—and designed for quick assembly. Team members learn they can't focus solely on any one parameter.

Members

The rules define contest bridges as consisting of two components—members and fasteners. Each bridge member must fit inside a 6-in. by 6-in. by 36-in. wooden box, precluding the use of any extra-long members. Additionally, no single member may weigh more than 20 pounds. These bridges are 1:10 scale models, so this reflects real-world limitations on fabrication, shipping and maneuverability limitations. For 2010, the rules placed an increased value on stiffness, penalizing higher deflection more than increased weight.

Connections and Tools

Making connections is one of the necessities of any construction project. But when the criteria for success include both speed of construction and the strength of the resulting structure, the importance of good connection design rises to the top of the list.

The contest rules stipulate that each member-to-member connection must have a bolt and nut, which in turn must be off-the-shelf products (standard sizes, not ground to a taper, no tapped holes, etc.). Many entries featured machined connections developed as "quick-connect" type of fittings for which fasteners were included



Above, right: The University of Wyoming bridge used a split truss approach, joining top and bottom members with goof-proof connections. The bolts hold them together while additional pairs of pins and holes carry member forces. At the supports, a similarly simple connection was used.



Below: The Université Laval (ESUL) team designed its deck support as an integral part of the main bridge members. Judges use the wooden box in the background to check that all members are within the maximum size limits.



Senior editor Thomas L. Klemens, P.E. joined the staff of Modern Steel Construction in 2009. An avid bridge fan, his enthusiasm for field experience goes back to his own student days when he took a job immediately after graduation as the assistant field engineer (i.e., surveyor's helper) on a bridge reconstruction project in Pittsburgh.



Left: The New Jersey Institute of Technology's highly fabricated bridge members, officially staged and ready for the competition, with groups of fasteners in the forward staging area. The construction site begins 30 ft beyond where the fasteners are.



Clemson University team members learned TIG and MIG welding in the process of fabricating their bridge. Team members several years ago used their newly acquired skills to produce these team mascots.

Above, below: The University of California at Davis design included several custom tools for holding members in place and making connections, shown below in the staging area and above in use during construction.



The University of Wyoming's bridge identification plate includes the school trademark, a cowboy on horseback, in a style matching the member fabrication.

primarily to meet contest requirements. Also, dropped fasteners incur penalties, so teams find clever ways to avoid that. (To see examples of this and other ideas discussed in this article, go to www.modernsteel.com/photos.)

In practice, straightforward moment connections seemed to be the best performers this year, but require careful fabrication to facilitate construction. The difference between good and not-so-good connections often could be gauged by whether the team kept a rubber mallet "persuader" close by.

Lessons Learned

Through participating in this very real design and construction project, students learned first hand that:

- Planning, constructibility and practice are *all* required for success.
- Rules, and by extension real-world specs and drawings, can have varying interpretations. The Rules Committee each year handles dozens of questions, and students learn the importance of asking for clarification.

- Devising a solution includes choosing among several good proposals, often melding the best parts of each.

- Achieving team motivation and coordination is not easy, but as competitive teams know, it isn't just about the bridge, it's about the bridge builders, too. Success depends upon the ability to plan and work as a group.

- Given the complex interactions of many parameters, there's nothing simple about designing and constructing a steel bridge.

Wrapping Up

Photos of the 2010 competition and a list of winners is available at www.aisc.org/steelbridge, where the rules for the 2011 National Student Steel Bridge Competition will be posted in late summer. A detailed spreadsheet of each national finalist team's category-by-category scores is at www.nssbc.info, in the History and Results section. That site also offers a participant guide, the official rules dating back to 2001, and results from 2003 to date.

MSC

The Road to Repair

BY MARTIN ANDERSON

Heat straightening can be an effective tool in working with damaged steel members.

DESPITE EVERYONE'S BEST EFFORTS, structural steel members can become damaged in the field. Forklifts may hit unprotected columns, overheight trucks can strike bridge girders, and so on. Fortunately, in many instances the damaged steel can be repaired (brought back into acceptable tolerances) in the field with a technique known as heat straightening. It is an appealing method of repair for structural steel as it can be performed in-place, does not require adding material to the member, and may not require temporary shoring, potentially saving both time and money.

Heat straightening is the process of applying heat in conjunction with passive restraint to produce permanent localized deformation that counteracts undesired deformations. The keys are that hot steel has a lower yield point than cold steel, that steel expands when heated and contracts when cooled, and that this expansion/contraction can be made asymmetric through judicious use of passive restraint.

Passive restraint can be (and often is) provided by jacks. However, the most important mode of restraint occurs within the steel itself, as an internal restraint caused by thermal gradients within the material. Cooler areas of steel tend to impede the thermal expansion of heated areas, causing plastic deformation in the heated area and corresponding changes in the shape of the member. Controlling the deformation is largely a matter of setting up and controlling thermal gradients in the steel; rather than directly shaping the member by applying force to it, the steel shapes itself as it reacts to temperature differences created by applying heat.

Consider the example of applying heat to a triangular region across the width and roughly in the middle of a short steel bar, laid flat. As the heated area attempts to expand the colder areas will prevent it from doing so. The base of the triangle will expand more than the apex, causing the bar to bend toward the apex of the heated region. As the steel cools, greater contraction will occur at the base of the triangular heated region, resulting in a permanent bend without the application of external force. If desired, this bend can be enhanced by using additional external passive restraints during the heating phase.

You may wonder, at this point, if we couldn't accelerate the process further by aggressively tightening the clamp (by using active jacks, for example) and using more heat to

lower the yield point even further. These are both bad ideas. First, heating must be done judiciously, especially in the field, because it may change the material properties of the steel. It must stay safely below the lower phase transition temperature (which is about 1,300 °F/700 °C, depending on material). Second, applying significant force while the steel is hot risks pushing the steel well beyond yielding, potentially resulting in rupture, unexpected crimps, buckling, and other undesirable distortions.

"Hot mechanical straightening" and "hot working" are different from heat straightening. They may be acceptable in some applications but not as unplanned variations on heat straightening in the field. Hot mechanical straightening

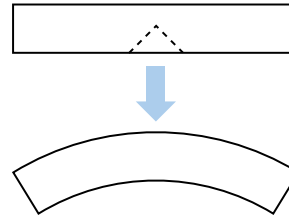
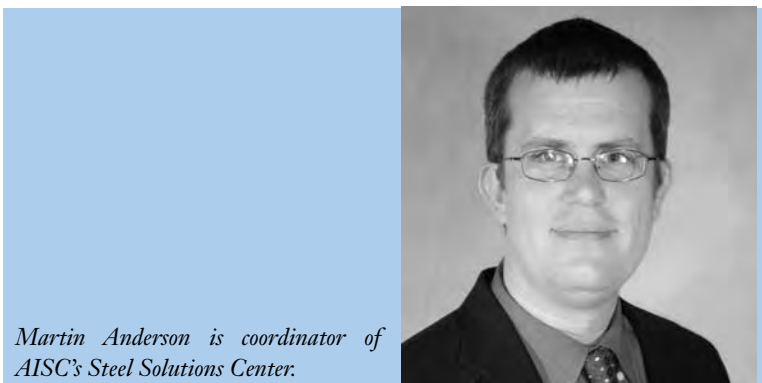


Fig. 1

generally involves application of large forces, attempting to straighten the deformation in a single heating cycle. While this can be an effective repair method for structural steel, it risks rupture or localized distortion and is difficult to perform in the field. Hot working, meanwhile, involves very high heat and the application of large forces. Because temperatures greater than 1,300 °F (700 °C) can change the properties of some steels, they are not permitted by the AISC *Specification*.



Martin Anderson is coordinator of AISC's Steel Solutions Center.

Damage Patterns

Before designing a repair methodology, one must first analyze the damage. Most of the research on heat straightening recognizes the same four fundamental types of damage, each with a corresponding shorthand designation:

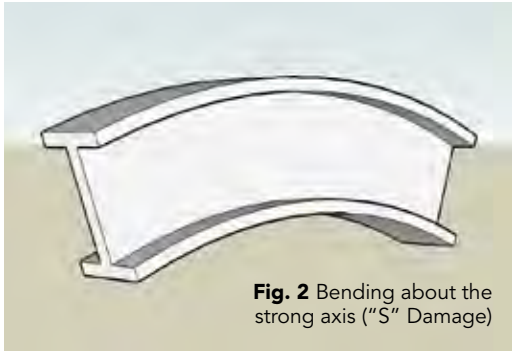


Fig. 2 Bending about the strong axis ("S" Damage)

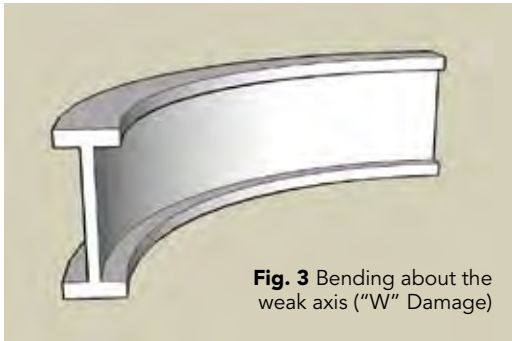


Fig. 3 Bending about the weak axis ("W" Damage)

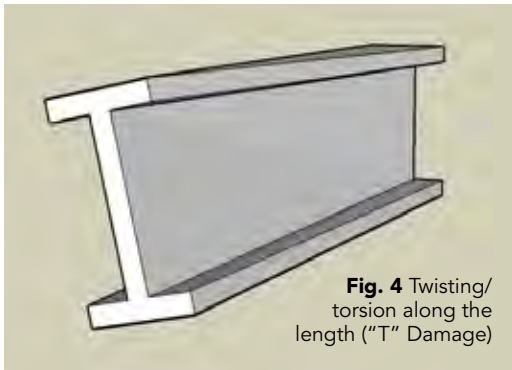


Fig. 4 Twisting/torsion along the length ("T" Damage)

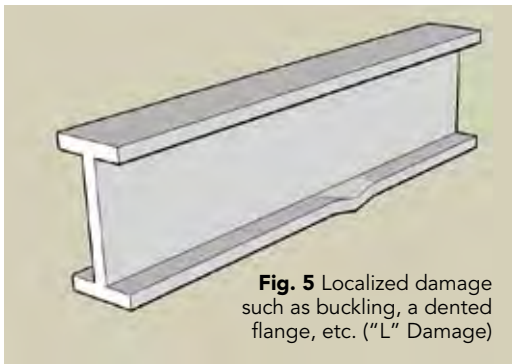


Fig. 5 Localized damage such as buckling, a dented flange, etc. ("L" Damage)

In most cases the actual damage sustained will be a combination of these basic four damage patterns. For example, a beam struck by a truck may have local bending at the flange as well as torsion and/or weak-axis bending. A crucial step in heat straightening is to correctly characterize the damage so that a suitable repair methodology can be established. Many of the core texts on heat straightening make specific recommendations regarding appropriate repair methodologies for each type of damage as well as how to address the various combinations.

Heat Patterns

Just as there are four damage categories there are four basic ways to apply heat to a wide-flange section. These can be combined (simultaneously or in sequence) to create complex heating designs for the specific damage being repaired.

- Spot: a small circular area is heated without moving the torch very far. Be warned, it is easy to accidentally over-heat the steel with this pattern.



Fig. 6 Spot Heat

- Line: a straight pass of the torch in one direction. Some refer to an "edge" heat, which is a line heat along the edge of a member (such as along a flange tip).

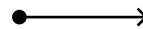


Fig. 7 Line Heat

- Strip: sometimes referred to as a "rectangular" heat, this pattern involves repeated passes of the torch progressively back and forth across a rectangular area.

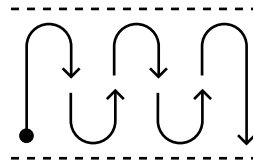


Fig. 8 Strip Heat

- Vee: perhaps the most-used heating pattern. A small spot is heated, serving as the apex of a triangle. As the torch is swept back and forth, the length of the sweep increases, gradually creating a triangular heated region.

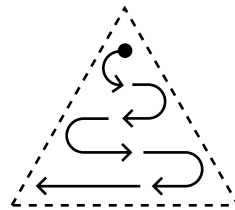


Fig. 9 Vee Heat

What About Columns?

Heat straightening is most commonly applied to beams, but it can be used to remove distortion in axially-loaded members as well. However it is important to consider the existing loads before applying heat. Local eccentricity of the axial column load may create a moment that will impede heat straightening or make the distortion worse. To overcome that, you may wish to consider using a jacking force to produce

an opposing moment equal to the axial compressive force at the point of damage. In addition, P -delta effects should be considered.

What About Fatigue?

Heat straightening of fatigue-sensitive members requires additional consideration and planning, and should not be undertaken without careful inspection of the damaged area for nicks, cracks, or anything else that could serve as crack initiation points. All such imperfections should be ground smooth before applying heat. Weld toes should be ground smooth to avoid stress concentrations, and nondestructive testing (NDT) should be used throughout the process to ensure that cracks are not occurring during the repair. For best results, these members should not be repaired more than twice in the same damage area.

Tips & General Suggestions:

- Do not use a cutting torch. This may seem obvious, but it's important.
- Use an appropriate tip on the heating torch. Thicker steel requires more heat, but delivering this heat without overdoing it becomes problematic. The Federal Highway Administration (FHWA) document in the list of resources below includes specific suggestions. The document recommends starting at a single-orifice size 3 tip for steel less than a ¼-in. thick, single-orifice size 8 or multi-flame (rosebud) size 3 for steel up to 1 in. thickness, and multi-flame size 5 for steel 3 in. thick or greater.
- Do not try to heat an excessively large area; because you are relying in part on the restraint provided by cooler sections of steel, heating a very large area will tend to reduce efficiency.
- Do not heat the steel outside the area that yielded during the damaging event. This is pointless, and reduces efficiency.
- Always observe the maximum temperature rules stated in Section M2.1 of the AISC *Specification for Structural Steel Buildings*, as well as the AASHTO/AWS D1.5M/D1.5 *Bridge Welding Code*. For carbon steel, keep the temperature below 1,200 °F (650 °C) at all times; other steel grades may have different temperature requirements, but always stay below the lower phase transition temperature. Using 1,200 °F (650 °C) for carbon steel gives a 120 °F (50 °C) margin of safety in case of operator variability, measurement error, and the like.

- Remember that temperature crayons can burn when exposed to direct flame. You may wish to consider various forms of temperature monitoring. Infrared devices are increasingly affordable and accurate, but be sure you monitor the temperature of the steel, not the temperature of the flame. Measuring temperature is not as easy as it may at first appear, and care should be taken at all times to ensure accurate readings.
- Do not actively cool the steel (for example, by water spray or compressed air) until it has cooled to below 600 °F (315 °C) to keep from creating brittle zones in the member.
- Do not reheat the steel until it has cooled below 250 °F (120 °C) or you risk additional damage.
- When applying restraint with jacks, calibrate and monitor the jacking forces to avoid over-jacking and potentially damaging the member. MSC

Selected Resources

Additional information on heat straightening repair of structural steel can be found in these documents:

- “What You Should Know About Heat Straightening Repair of Damaged Steel,” by R. Richard Avent and David J. Mukai, *Engineering Journal*, First Quarter 2001, available online at www.aisc.org/epubs.
- “Heat-Straightening Repairs of Damaged Steel Bridges: A Technical Guide and Manual of Practice,” Report No. FHWA-IF-99-004, U.S. Department of Transportation, Federal Highway Administration, available online at www.fhwa.dot.gov/bridge/steel.
- “Heat-Straightening Repair of Damaged Steel Bridge Girders: Fatigue and Fracture Performance,” NCHRP Report 604, Transportation Research Board of the National Academies, available online at www.trb.org/Main/Public/Blurbs/160020.aspx.
- “Engineered Heat Straightening Comes of Age,” by R. Richard Avent, P.E., *Modern Steel Construction*, February 1995, available online at www.modernsteel.com/backissues.



When an intense fire destroyed the 9 Mile Road bridge, designers took the opportunity to also accommodate future plans.



Emergency Renovation

BY JEREMY HEDDEN, PE., MARIO QUAGLIATA, PE., AND TOM WANDZILAK

ON THE EVENING OF JULY 15, 2009, a fuel tanker traveling on I-75 just north of Detroit struck a column supporting the 9 Mile Road bridge in the city of Hazel Park, Mich. As a result of the ensuing explosion and fire under the northbound portion of the bridge, that section collapsed onto the heavily traveled interstate. Fortunately there were no fatalities, and I-75 was cleared, repaired and reopened to traffic within the week. The 9 Mile Road bridge, however, was beyond repair. Replacing the bridge and reopening this major east-west thoroughfare became a top priority for the Michigan Department of Transportation (MDOT).

Ironically, the 9 Mile Road bridge had recently been restored as part of a \$16.5 million MDOT project to restore 16 overpasses. Rather than simply rebuild the crossing, however, MDOT took the opportunity to accommodate future plans for the stretch of freeway in the design of the new bridge. A realignment of I-75 along the horizontal curve located at the 9 Mile Road overpass

was already in the planning stages, with the goals of shifting the freeway median to the east approximately 15 ft and widening the freeway to five lanes in each direction.

Normally, designing and building a bridge takes several years. Planning, requesting proposals for design services, awarding the design contract and completing design services typically take between one and two years. The project is then advertised for construction, awarded, and built the following year. However, this project required a different approach in order to reconnect the city of Hazel Park along this vital roadway as quickly as possible. Just two months after the collapse, MDOT advertised a request for proposal. On September 30, 2009, a design-build team was selected to replace the bridge and rebuild the freeway below.

The design team was led by Fishbeck, Thompson, Carr, and Huber in Farmington Hills, Mich. (freeway design) and Bergmann Associates in Lansing, Mich. (bridge design). The key to meeting all of the project requirements within a very aggressive



Bergmann Associates

Steel plate girders provide a clean, low-profile appearance and offer plenty of clearance below the new 9 Mile Road bridge even though the alignment stayed the same and the span increased.

schedule was the inclusion of structural steel plate girders for the new superstructure. The structural steel option provided a low profile superstructure, flexibility in meeting the complex geometry requirements, quick construction, and aesthetic appeal.

Design For the Future

The new structure had to accommodate both the geometry of the proposed immediate solution and the plans for future I-75 realignment and expansion. The freeway width was too great to provide a single span that would allow for a future median shift with no influence on the structure. Consequently, a bridge was designed with both a proposed median pier and a future median pier in mind. The proposed pier, constructed as part of the immediate replacement, is skewed to match the existing freeway horizontal alignment.

The future pier was designed to match the skew created along the median in the future and will match the abutment alignment. However, only the foundation piling for the future pier was constructed as part of this project. When I-75 is widened and realigned, the new pier will be constructed atop the foundation piling installed as part of this project. After it is built, the weight of the bridge will be shifted to its new center support and the “proposed” pier will then be removed.

Accommodating both future and proposed conditions made design of the superstructure much more complex with respect to capacity and detailing. During pre-bid, the D/B team focused on providing a superstructure that could be built quickly, be cost-effective, and could accommodate a

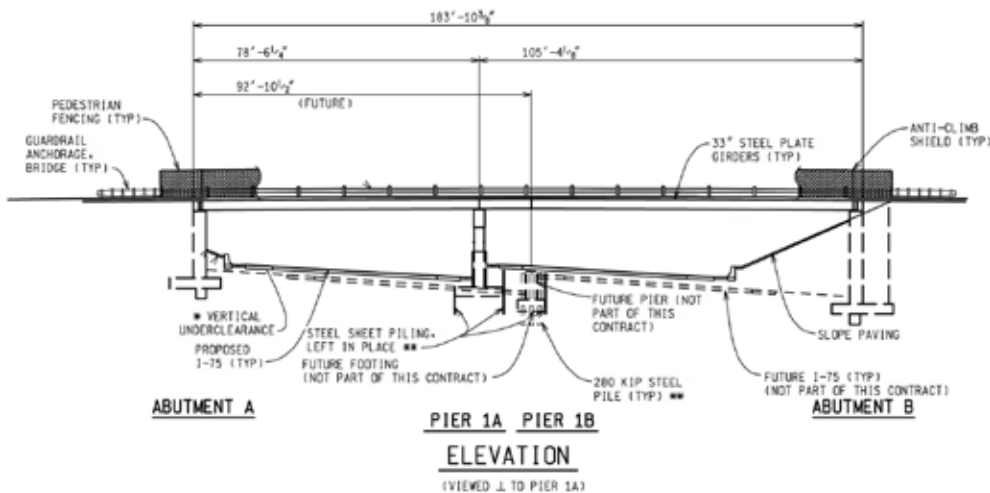
shift in the center support, while meeting the stringent geometric constraints on the project. Continuous steel plate girders with a composite concrete deck provided the solution. “With the complex nature of the superstructure, a large bulk of the steel design was done during the pre-bid phase to ensure that material was readily available and bid prices were as accurate as possible,” said Mario Quagliata, project engineer at Bergmann Associates.

Concrete options were considered during the pre-bid phase, however, there were several insurmountable challenges associated with each of them. First, the future pier shift would have made design and detailing of a prestressed beam difficult and also would have required post tensioning. The team needed a solution that was proven, familiar to the contractor, and easily constructible. Second, the tight geometric constraints associated with the site required that a thin superstructure be used. Concrete options did not offer this advantage. Finally, the team needed to be able to secure the materials quickly. Because this was a design/build project, the team was able to take advantage of the materials available from the fabricator and streamline design plan and shop drawing development.

Bergmann Associates and general contractor Walter Toebe Construction, Wixom, Mich., coordinated with Lancaster, Pa.-based High Steel Structures on the steel fabrication, quickly proceeding with preliminary design concepts that could take advantage of the steel plate on the ground at High Steel’s facility and plate that could be obtained quickly from the steel mills.

Jeremy Hedden, P.E., is a project manager and Mario Quagliata, P.E., is a project engineer with Bergmann Associates, Inc. Tom Wandzilak is business development manager for High Steel Structures, Inc.





The immediate replacement bridge used a new pier (1A) in the existing median. A new foundation was also installed to accommodate construction of a replacement center pier (1B) when the highway is realigned.

The design of the two-span continuous steel plate girders accommodated an unusually large negative moment region as a result of the varying median pier location. The benefits of a composite deck were significantly reduced because of the large negative moment envelope. This in turn resulted in a challenge to provide an acceptable beam depth which would allow for sufficient clearance for the Interstate below while not affecting the existing intersections located immediately adjacent to the ends of the structure above.

The resulting plate girder design consisted of a 33-in. by 3/8-in. web and 20-in.-wide flanges ranging in thickness from 1.5 in. to 2 in. The span lengths totaled 191 ft, 10 in. with individual unbalanced span lengths varying along each girder line from 78 ft, 6 in. to 113 ft, 4 in.). Bearing stiffeners were designed and fabricated at each abutment support line, the proposed pier support line, and the future pier support line. Shear studs were omitted throughout the entire negative moment envelope created by both proposed and future conditions. The steel conforms to AASHTO M270 Grade 50W and is protected with a three-coat shop paint system.

Splice Design

Typically the field splices for a plate girder would be located at the points of contraflexure along the beam. However, with consideration for a future pier shift in mind, the splice design had to accommodate much larger bending stresses than would normally be encountered. The splice detail had thicker and longer plates as a result. The layout of the intermediate diaphragms also had to accommodate the future shift in the median pier which, along with the larger field splices, created challenges in the framing plan geometry. Close coordination between the engineer and the fabricator on details of the field splices, diaphragms, and conduit supports ensured fabrication could be completed within congested areas of the plate girders.

The team designed the camber for the new plate girders to accommodate the proposed bridge conditions. However, an analysis also was performed to check the deflected shape of the superstructure after shifting the center support. The results showed that there would be no reduction in the design vertical underclearance for



Steel plate girders for the replacement 9 Mile Road bridge over I-75 were delivered to the contractor's staging area for quick job site deployment and erection when the piers were completed.

Point Blank Heat

When the tanker exploded around 8 p.m. on July 15, 2009, it was filled with about 13,000 gallons of fuel. An investigation showed that a speeding driver hit the tanker, causing it to jack-knife and burst into flames under the northbound portion of the 9 Mile Road bridge. That portion of the bridge quickly collapsed onto the tractor, leaving both the tanker and the tractor-trailer crumpled and burnt. Three persons suffered burns and other injuries, and were transported to hospitals by ambulance for treatment.





All the beams for the 9 Mile Road replacement bridge were set on three consecutive November nights, with one direction of the Interstate below closed to traffic.

the bridge and there would not be significant alterations to the rideability of the roadway above.

High Steel was given notification to proceed with the fabrication on October 2, 2009. On November 13, diaphragms and bolts began arriving at the job site, followed by steel girders four days later. The beams were set during three consecutive nightly, single-bound closures of I-75.

With the structural steel being one of the major critical path items of work, pressure was immediately on the design team. “We had our design team working day and night in order to complete the steel design as quickly as possible. Design plans were completed within two weeks of the notice of award,” said Jeremy Hedden, Bergmann Associates Project Manager. “I catered the dinners each night to keep everyone working as efficiently as possible.”

The shop drawing review process was streamlined by the fact that High Steel and Bergmann Associates coordinated details during their development. In the end, High Steel fabricated 317 tons of steel girders, representing \$1.1 million of the \$12 million bridge replacement and freeway reconstruction project.

Possibly the most important participant during the whole project was Mother Nature. Unseasonably warm temperatures and dry weather assisted the contractor with completing the work quickly. Placement and curing of the cast-in-place concrete deck was completed with the use of heaters from below and insulation above. With good weather and long hours by all involved, the bridge was opened to traffic on December 11, 2009, only 65 days after the project team’s notice of award.

MSC

Owner

Michigan Department of Transportation

Structural Engineer

Bergmann Associates, Lansing, Mich. (AISC Member)

Steel Fabricator

High Steel Structures, Lancaster, Pa. (AISC and NSBA Member)

General Contractor

Walter Toebe Construction, Wixom, Mich.



Artistic Flyover

BY OSCAR OLIDEN, P.E., AND GARY GARDNER

ISAAC MIDDLE SCHOOL in central Phoenix is located on McDowell Road, a major east-west artery that runs parallel to and about ½ mile north of the I-10 freeway. Every morning and afternoon, several hundred of the school's 1,000 year-round students cross the heavily traveled highway, which carries an estimated 30,000 cars per day.

After two student deaths, the city in 2005 conducted a feasibility study and identified the need for a pedestrian bridge to provide safe passage across the busy highway. The study coincided with efforts of the West Side Phoenix Revitalization Area (WPRA) to increase city services and infrastructure by partnering with residents. The project was also to incorporate public art associated with the beginnings of the neighborhood.

The city awarded the project to the team of Jacobs Engineering Group, Inc., Phoenix, and Bison Construction, Carson City, Nev. Jacobs, in conjunction with the city's Office of Arts and Culture, selected public artist Rosemary Lonewolf to participate in the development of the design and ultimate construction of the project.

The Jacobs Engineering team initiated a comprehensive public involvement and educational program. Several bi-lingual neighborhood public meetings took place to educate, inform, and develop understanding of the project and to gain its final approval. The team also provided educational inspiration to the Isaac Middle School students by conducting a series of engineering and art challenges, demonstrating how ideas can become reality.

Fast-tracking Design

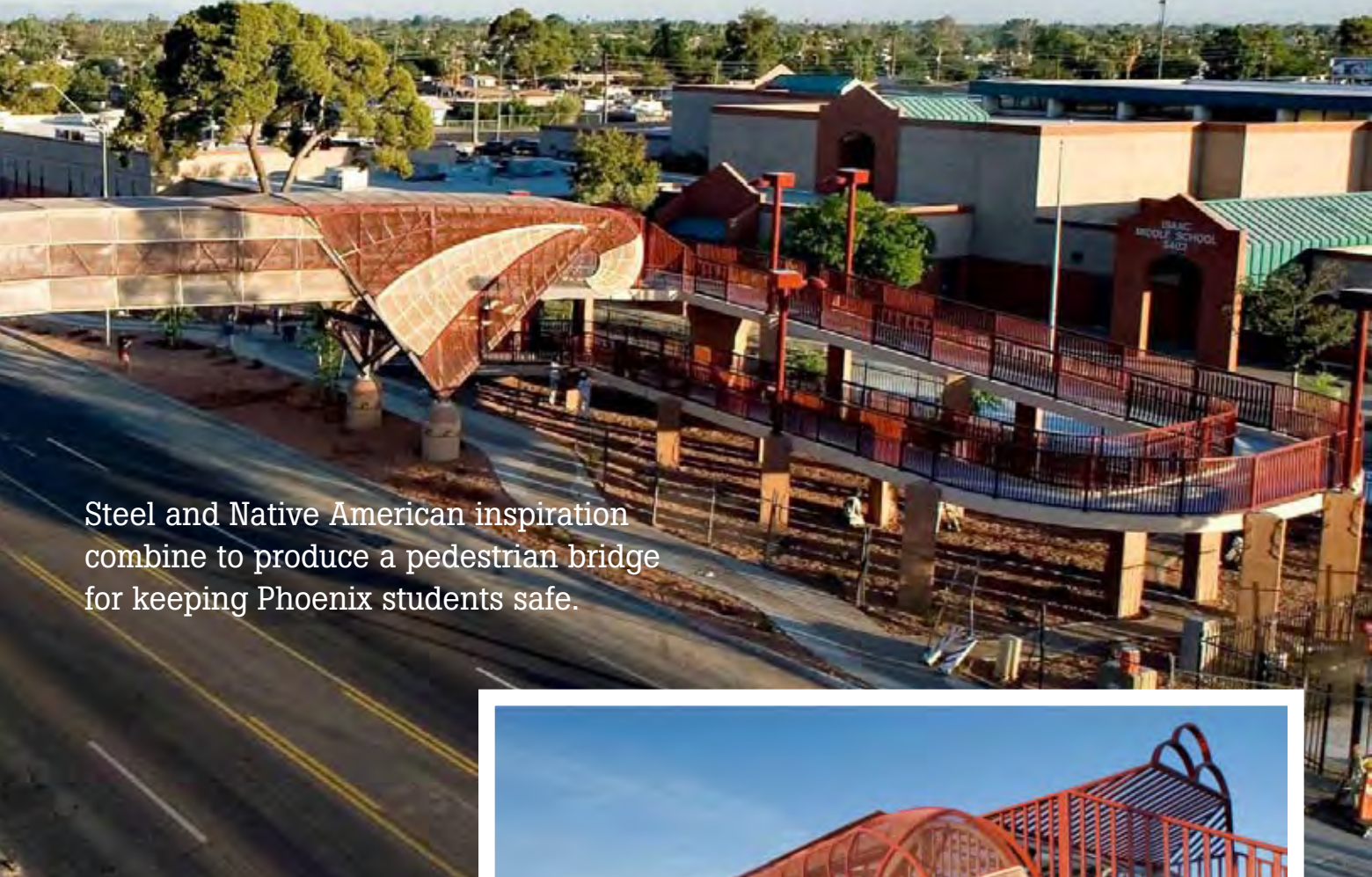
In less than six months the project team met the requirements for federal funding in association with the Arizona Department of Transportation (ADOT Local Government Section). This quick funding resulted directly from cooperation with the city, the Isaac community, ADOT, and congressman Ed Pastor. With funding in place, the fast-track process to design and build the project began.

To speed design, a partnership of ADOT, the city, and the project team minimized review times. A compressed review process allowed final design to begin well ahead of the typical waits for environmental clearances.

The team completed the initial project assessment in one month, including a public meeting to bring the project to the public for the first time. It completed the categorical exclusion within two months of project initiation. The 30% concept drawings were complete two months after receiving a notice-to-proceed from the city. The public and the city enthusiastically received the 70% design plans. Final design plans were completed and bid in 6½ months.

Designing For Constructability

During the design process, Jacobs invited all statewide certified steel bridge fabricators to review emerging design concepts and to offer comments regarding constructability. Their comments helped the artist to work with an eye toward engineering and helped Jacobs to arrive at a more accurate engineer's estimate and bring in an accurate bid.



Steel and Native American inspiration combine to produce a pedestrian bridge for keeping Phoenix students safe.

The Isaac Middle School Bridge in the center of Phoenix provides safe passage for hundreds of students going to school each day, while also paying tribute to the area's Native American heritage.

Jacobs designed the main span over McDowell Road as a fully enclosed structure to enhance student safety. The artistic treatment incorporated into the truss resulted from close collaboration between Jacobs and Lonewolf.

The final design called for a bridge about 90 ft long and 9 ft wide, along with 450 ft of total developed ramp length (225 ft at each end). The bridge span offers 8 ft of clearway width for pedestrians and bicycles along with 8.5 ft of headroom. It provides a clearance of 17.5 ft for vehicles on McDowell Road.

Incorporating Artistic Treatments

Introducing public art into a transportation project like a pedestrian bridge presents a variety of challenges. Incorporating artistic vision and defining the medium and materials were among the first issues addressed. The unique design of the Isaac Pedestrian Bridge resulted from a close collaboration between engineer and artist.

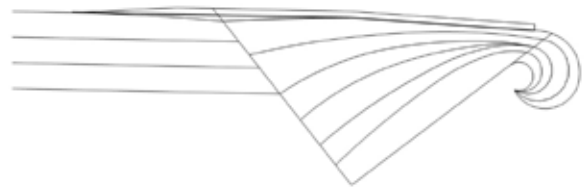
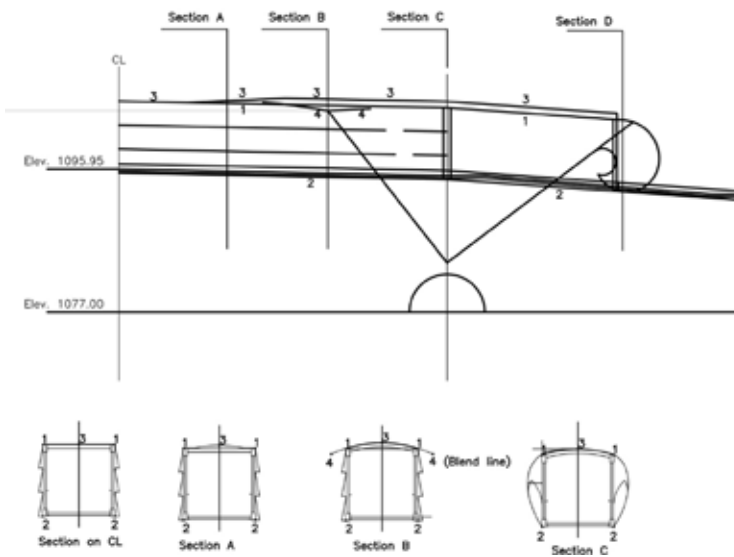


Inspired by images on early Native American pottery, artist Rosemary Lonewolf collaborated with the fabricator and engineer to incorporate shapes and colors reminiscent of macaws in flight.

photos this page by Craig Smith

Oscar Oliden, P.E., is project manager with Jacobs Engineering Group, Inc., Phoenix. Gary Gardner is a certified welding inspector and sustains the QC, welding, process, and materials engineering functions of Stinger Welding, Coolidge, Ariz.





Oscar Olden

One of Lonewolf's early clay models and its translation into structural sketches.



Stinger Welding Inc.

Above: Ultrasonic testing of full-penetration welds ensures they contain no inclusions or porosity and verifies that the welds are, in fact, full-penetration.

Below: Each piece of wing consists of several expanded metal sections, which required that workers be careful when welding it to the structural members to avoid damage from excessive heat.



Stinger Welding Inc.

Lonewolf, a Native American Pueblo Tewa Indian, drew her inspiration for the bridge's bird-like artistic treatments from the geometric images of parrots painted on prehistoric Native American pottery. Her vision started with a clay model of a parrot called the scarlet macaw. In the final design, steel wings of the macaw flying in opposite directions spread out over the canopy of the bridge from either entrance and on both sides.

Brightly-colored relief pictures on the bridge columns tell the story of ancient traders toting corn and other goods from one culture to another. In addition to the relief images on the columns, the bridge features designs for railings and smaller support piers, an abstracted motif of birds sand-blasted into the walkway, and red LED lighting to accent the bridge at night.

Design and construction issues relating to the bridge's footprint had to balance keeping existing landscape features and attaining available right of ways. The city's various owner departments streamlined the process by donating various rights of way. For example, a strip of land was transferred from the Isaac Middle School to McDowell Road. The final ramp layout avoided conflict with several existing trees to maintain local aesthetics.

Building the Bridge

Stinger Welding, an AISC-certified major bridge fabricator, built and painted the entire 75-ton bridge, along with the stairways and ramps, in its Coolidge, Ariz., shop. The company then transported the bridge truss to the project site and installed it on its four support pillars and welded the ramps and stairways into place.

Structural members for the 90-ft X-pattern truss and curved roof are ASTM A500 Grade B HSS that were hot-formed to conform to the design. The company's certified welders attached the truss members with open root, full penetration D1.1 welds followed by ultrasonic testing. Using gas-shielded flux-core arc welding (FCAW-g) exclusively ensured the strength and long-term integrity of all of the welds.

Expanded metal, rolled flat, encloses the entire bridge and makes up much of the art treatment and design patterns. Using cold-formed expanded metal to create the stylized macaws on each end and side of the bridge re-

quired a great deal of cutting and piecing, as well as care in welding.

Stinger built the truss and the four major stylized parrot art treatments separately, providing for attachment later via welding. Ramps and stairways also consist of welded rectangular HSS sections. Many verticals for the ramp and stairway railings are cut into a feather shape.

The design of the ramps and stairways purposely provided an open structure underneath for good security and visibility. The bridge floor consists of stay-in-place galvanized forms for the concrete decking added to the bridge after its installation.

Final Touches

Because aesthetics of the bridge were a significant concern, Lonewolf played a large role in selecting the three expanded metal types and railing designs, as well as colors for the paint and LED lighting. To make the bridge's decorative lighting more effective in highlighting the artistic treatments, Stinger attached small reflectors of sheet metal with a high-gloss finish. The reflectors direct light from the LEDs to the bridge surfaces, avoiding nighttime glare for motorists.

After the bridge truss had been rolled out into the yard and the end treatments had been attached, painters applied a great deal of masking to attain the variety of colors required. Coatings consisting of an organic zinc primer followed by two color coats and a clear anti-graffiti top coat were applied electrostatically for uniformity with minimum waste. Most of the painting occurred at night when cooler temperatures prevailed.

Installing the Bridge

Physical clearances and transportation limitations of the entire bridge span required that its mounting "feet" (attachments to the four pillars) be cut off, and reattached in the field. Ramps and stairways arrived in the form of panels and also were welded into place in the field.

Two key customization items—custom-designed light poles and customized feather shapes for the metal railings—contributed to the bridge's final cost of \$3.6 million exceeding the budget estimate of \$3.2 million. Although the original project schedule provided three years for design and construction, Jacobs and its partners completed the bridge in two years. The bridge opened for pedestrians in August of 2008.

Owner

City of Phoenix Street Transportation Department

Consulting Engineer and Project Manager

Jacobs Engineering Group, Inc., Phoenix

Steel Detailing, Fabrication and Erection

Stinger Welding Inc., Coolidge, Ariz. (AISC and NSBA Member)

General Contractor

Bison Contracting Company, Carson City, Nev.

Public Artist

Rosemary Lonewolf, Santa Clara Pueblo, N.M.

Structural Software

GTSTRUDL, Tekla Structures

Bender/Roller

Albina Pipe Bending Company, Inc. (AISC Member)



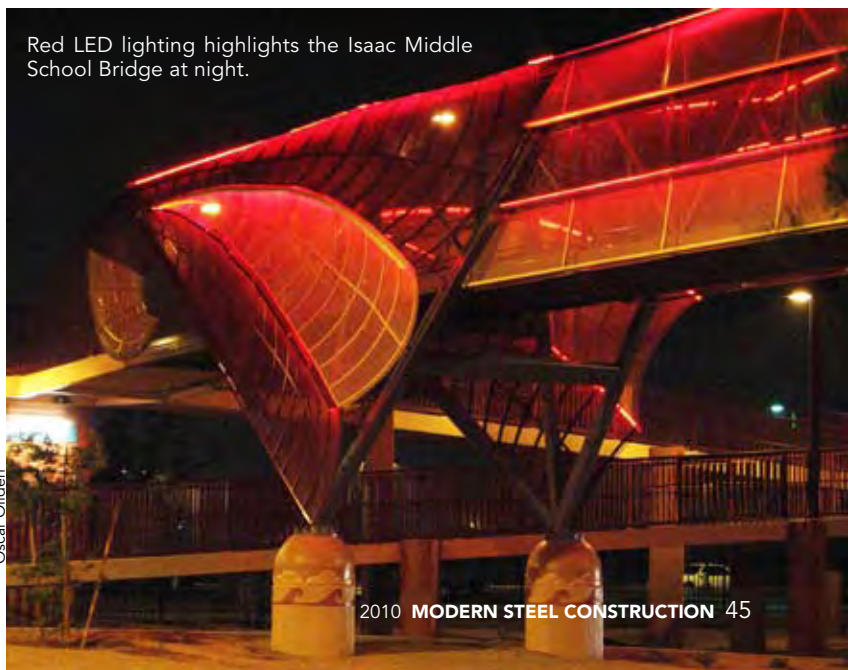
Stinger Welding Inc.

Painting often took place at night after temperatures had dropped. Prior to sandblasting and painting, Stinger rolled the bridge truss out of the shop, attached the stylized macaw head treatments at the ends, and masked as needed.



Stinger Welding Inc.

In addition to fabricating and painting the bridge, Stinger installed the structure onto its four support pillars, two each on the north and south sides of McDowell Road.



Oscar Olliden

Red LED lighting highlights the Isaac Middle School Bridge at night.

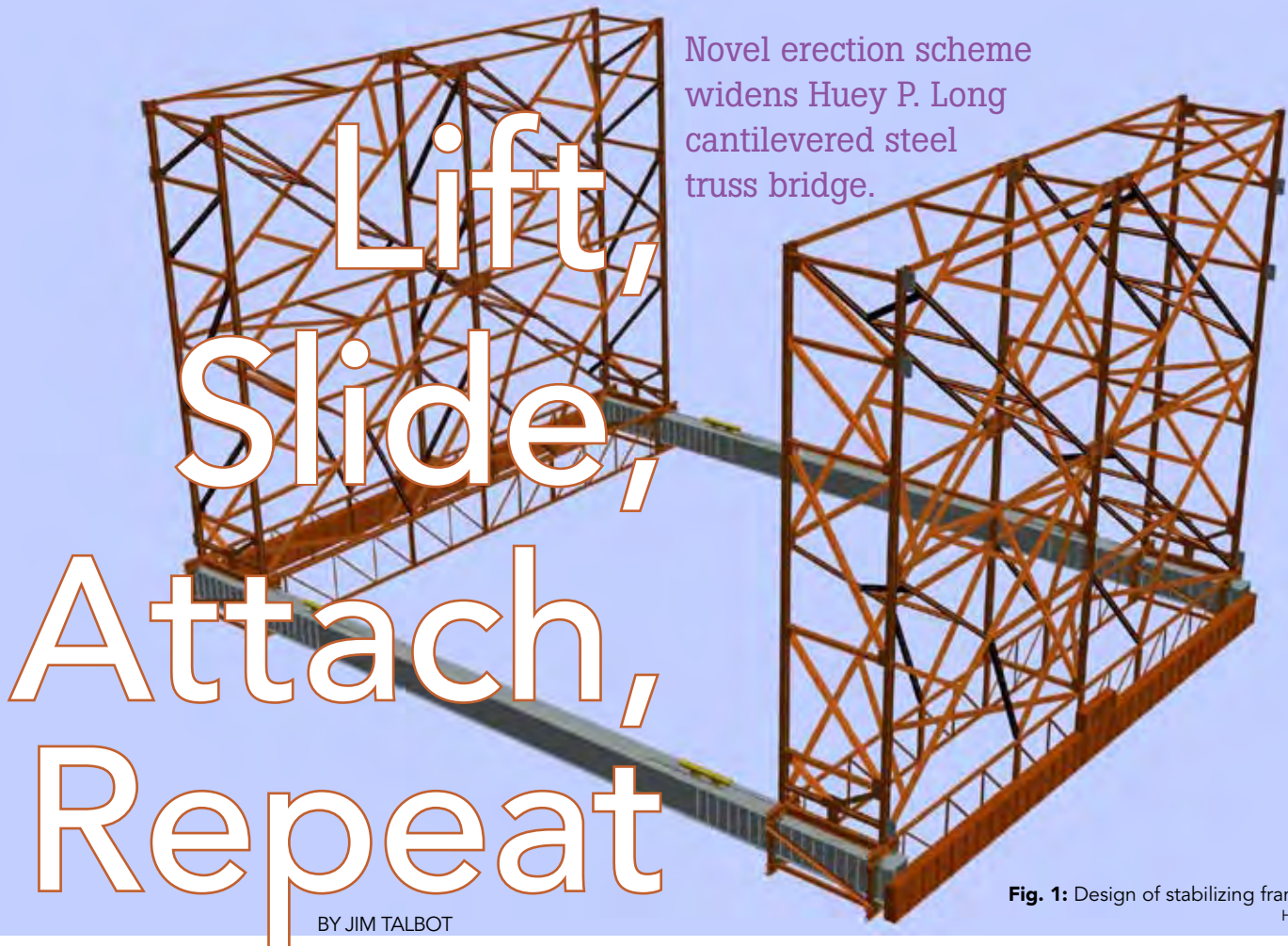


Fig. 1: Design of stabilizing frames. HNTB

Lift, Slide, Attach, Repeat

BY JIM TALBOT

THE FIRST LIFT in an innovative erection plan for new steel trusses to widen the 2,380-ft Huey P. Long bridge in New Orleans proved successful in June. The plan calls for simultaneously lifting a pair of truss panels—one on each side of the bridge—for three of the four main spans. Two of these truss lifts must first clear the recently widened piers. Then each truss panel must move 13 ft laterally back over the pier before being set down on bearings. This combination of lifting and lateral movement for a large pair of truss panels had never before been tried.

Modjeski and Masters originally envisioned that the widening truss would be erected by a traditional stick-build erection method. MTI and HNTB had two primary concerns about the stick-build method that were the genesis of a modified plan. The risk of a ship impacting the required falsework was a huge concern. In addition, during construction some truss panel points were estimated to be as much as 11 in. higher or lower than the existing truss until they displaced into their final position. Fit up would have required many temporary slotted and rotational connections, complicating erection.

The span-by-span erection lift method solves both concerns. It avoids the falsework in the river plus the need to install 30-ft diameter massive dolphins in front of each in 100 ft of water. And it leads to less than 3 in. of differential displacement between the existing and widening trusses at any time. Once crews make the permanent secondary member connections between the existing and widening trusses, deflection differences fall to less than an inch.

Developing an Erection Plan

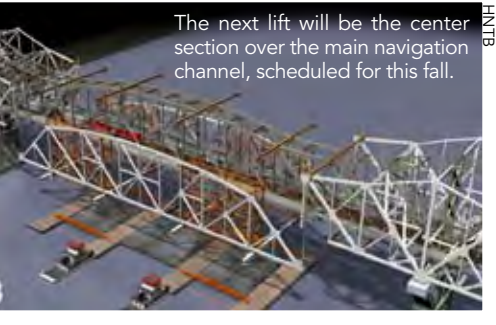
Completed in 1935, the Huey P. Long bridge is a three-span continuous cantilever truss plus an adjacent 530-ft simple-span

through truss. Two rail tracks run between the two truss sides. Two cantilevered 9-ft lanes with no shoulders for road traffic sit outboard of the truss on each side. The bridge serves as one of three major Mississippi River crossings in the New Orleans metro area and has daily traffic counts of more than 50,000.

Its widening is being funded by the Louisiana Transportation Infrastructure Model for Economic Development Program (TIMED). Louisiana TIMED Managers (LTM), a consortium comprising three companies: Parsons Brinkerhoff, GEC Inc., and the LPA Group, administers contracts for the Louisiana Department of Transportation and Development, primarily on road and bridge projects. LTM handles such functions as RFI submittals, public outreach, quality assurance, changes, fabrication inspection, and other general construction management tasks.

According to Tim Todd, LTM resident engineer, the widening of the Huey P. Long bridge superstructure is the third phase of a four-phase project. The first two phases involved substructure and railroad modifications. The final phase involves infrastructure and approach work. Todd says that each direction of the widened bridge will have three 11-ft driving lanes along with an 8-ft outside shoulder and a 2-ft inside shoulder.

One of LTM's tasks has been to build community support for the project. That support was a big factor in the success of the first lift in June. Bridge closings, which typically are not well received, to that point had generated just a single public complaint.



The next lift will be the center section over the main navigation channel, scheduled for this fall.

HNTB



Fig. 2: Erection of stabilizing frames and truss panels on barges north of the bridge.

MTI (Massman/Traylor/IHI)

der. The bridge widening project adds two new steel trusses to the existing superstructure to form an integrated four-plane truss system.

Contractor MTI—a joint venture of Massman Construction Co., Traylor Bros. Inc., and IHI Inc.—hired HNTB to devise the erection plan. “Taking this unique erection technique from concept to reality was a collaborative effort between MTI, HNTB, Mammoet, LTM and Modjeski and Masters,” said HNTB’s John P. Brestin, S.E., P.E. “It could not have happened without everyone on the team pulling in the same direction.” Brestin and Sean T. Cooney, P.E., also with HNTB, described the plan in November 2009 in a presentation at the World Steel Bridge Symposium. Their paper is available as a free download at www.aisc.org/wsbs.

Widening a Cantilever Truss

The first step was widening the existing piers. “Essentially a new concrete jacket surrounds the original piers,” Brestin said, “leaving a ledge near the top. A new steel pier truss sits on the ledge and widens the pier sufficiently to carry the new bridge truss panels.” That configuration means that during lifting, the new truss panels have to clear the pier edges, and then move inward horizontally to their final position above the bearings.

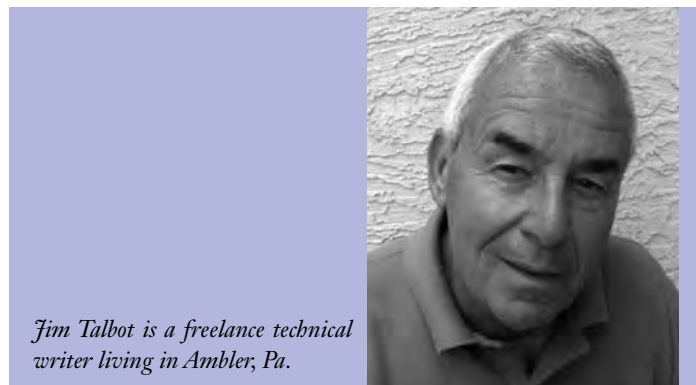
Brestin said a key to successful lifts is the design of a lifting and stabilizing frame (see Figure 1). “The same stabilizing frames serve for all three truss lifts,” Brestin said. “They basically consist of space frames mounted on two main floor beams. Lifting the truss panels from their bottom corners puts the top truss chords in compression. They would tend to buckle. The space frames provide the support necessary to prevent buckling during the lift.”

Four frames—two on each side—take part in each lift. The frames themselves mount on floor beam sleeves. Hillman rollers, mounted to all four interior surfaces of the sleeve assembly, allow the frames and attached truss panels to ride along the floor beams laterally.

Once the whole system of lifting frames with truss panels reaches the desired height above and outside of the piers, horizontal jacks move the frames with truss panels toward each other until the panels are about 6 in. above their bearings. “This lateral movement problem is what we scratched our heads about for some time—figuring out how to move the panels horizontally while keeping them stable,” Brestin said.

Lifting and Positioning the Truss Panels

For the first lift, MTI devised a platform of four barges (see Figure 2), connected by three sectional barges. MTI crews first



Jim Talbot is a freelance technical writer living in Ambler, Pa.

Fig. 3: Double-box beam, mounted on temporary tower on pier, supports 900-ton strand jack.

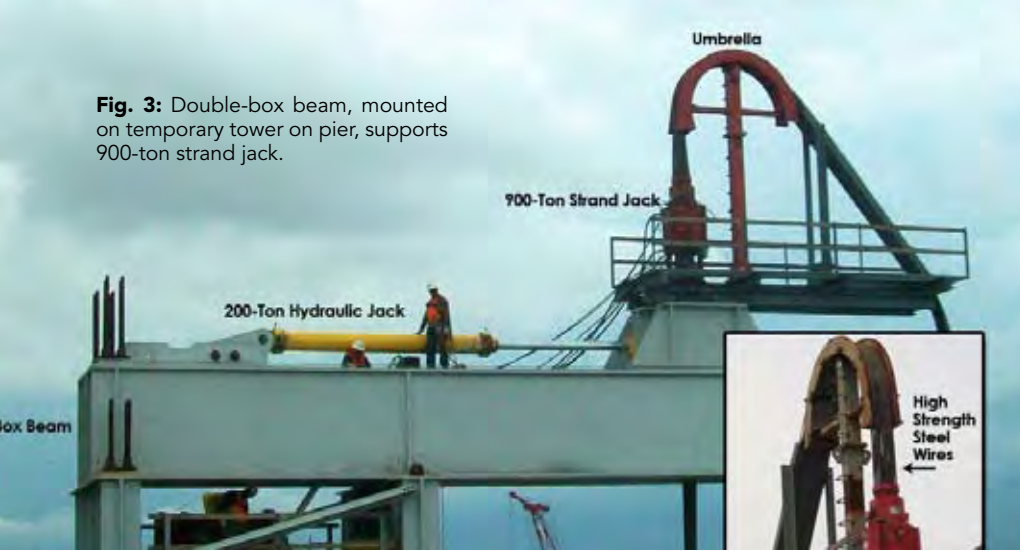


Fig. 4: Widened piers with temporary lift towers prior to lift.



Fig. 5: Barges, stabilizing frames, and truss panels in position for lift.



erected the stabilizing frames on the barge assembly, which was moored north of the bridge. Then, using the stick-by-stick method, they erected the two widening truss panels, attaching them to the stabilizing frames for lateral support.

Meanwhile MTI erected temporary towers on the four edges of the permanent pier trusses (see Figure 3). Each tower supports a double box beam that cantilevers over the edge of the pier trusses. A strand jack mounted atop each beam provides the force to lift the truss panels from the four bottom panel corners along with the attached stabilizing frames.

The strand jacks are mounted on sleds that can move transversely. The sleds permit the truss panels to be jacked back horizontally into position over the bearings after the vertical lift clears the piers. Teflon surfaces and stainless steel lubricated with dish soap promote the sliding sled movement.

Preparations for the first span lift, for the east anchor span, were ready by early June. On Friday morning, June 18, the river was closed down for eight hours to position the barges and spans in the auxiliary channel where the lift occurred. At 5 p.m. the barges were in position and the adjacent main navigation channel was opened for river traffic. The roadway and train traffic were unaffected during all that time. The next morning at 5 a.m. the bridge was closed to the public for the weekend, except for emergency traffic on one side of the bridge.

“At that time the river was closed for four hours to prevent ship wakes from the main channel that might affect liftoff—a sensitive time” Brestin said. “By 9 a.m. the lifting frame and truss panels were clear of the barges, and we opened river traffic in the main navigation channel.”

Applied Geomechanics Inc. (AGI), a consultant to MTI, set up a system of tilt meters and lasers to monitor any distortions of the truss panels during their lift and installation. Real-time monitoring helped to speed any adjustments necessary to keep the panels level and to check for indications of buckling. Mammoet could adjust the nominal 16-in. stroke of the strand jacks to compensate for any differences in lift heights at each corner. With each stroke the lifting properties of individual strand jacks became apparent so that the second half of the lift required virtually no adjustments.

Once the 2,600-ton assembly cleared the barges, the strand jacks raised the panel trusses 150 ft to an elevation about 6 in. above their final elevation. At that point, MTI braced the stability frames to the bottom chord of the existing truss.

“We planned to close down rail traffic to avoid vibrations while the truss panels were each moved 13 ft laterally over their bearings,” Brestin said. “One train got through, shaking the panels and making us all a bit nervous.”

Six horizontal jacks like that shown in Figure 7 moved each truss panel laterally, while the monitoring system helped keep them in a plane parallel to the existing truss. One control room controlled the jacks while another monitored the truss panels.

Once the panels rested on their bearings, crews attached temporary horn beams—pre-installed on the top of the existing truss—from panel to panel to stabilize them from the top chords. Then they braced the bottom chords against the existing truss. Once these members were in place, MTI disconnected the stabilizing frame. Four strand jacks attached to each truss panel lowered the stabilizing frame back down to the barge.”



Fig. 6: Lifting frame with new truss panels in mid-lift.



Fig. 7: Horizontal jack slides sled-mounted strand jack 13 feet, carrying truss panel over its bearing.

Photos by LA TIMED Managers/LaDOTD

The existing bridge was opened to road traffic by 9 p.m. Sunday, eight hours earlier than originally expected.

Lifting the Suspension Span

Brestin said the next lift will be the suspension span over the main navigation channel, scheduled for October or early November. “That lift is actually more critical because it’s in the middle of the main navigation channel,” he said. “We understand that the lift will affect just three deep draft vessels over the 48 hours of closure. MTI will have to brace the panels at the top quickly and then get out of the way—no breaks.” Shallower draft vessels will still be able to use the auxiliary channel under the east anchor span.

MTI has already completed a modified stick build of the west anchor span and added a cantilevered arm for connection to the suspended span. Crews are building the corresponding cantilevered arm on the recently lifted east anchor span in the same manner, using cranes on barges in the river.

For the modified stick build, the arms contain all the primary truss members but only some of the secondary members, Brestin said. Once these cantilevered sections are in place, MTI can raise the suspended span. The stabilizing frames are being used for all three span lifts because lifted span lengths are all about 530 ft.

The truss panels for the lift of the suspension span do not have to clear piers. MTI will lift those panels straight up using four strand jacks mounted on the stick-built cantilevered arms of the anchor spans. Very little lateral adjustment will be necessary once the truss panels are up. The weight of the suspended span will cause the an-

chor spans to deflect upward, but strategically placed ballast will keep the anchor span deflections within an acceptable range.

The last span lift for the through truss section is expected in the spring of 2011. This lift will be similar to that of the first east anchor span. Contracts call for the widening of the bridge to be complete by early 2013. MSC

Owner

Louisiana Department of Transportation

Design

Modjeski and Masters, New Orleans (AISC Member)

Steel Fabricator

Industrial Steel Construction, Gary, Ind. (AISC and NSBA Member)

Construction Manager

Louisiana TIMED Managers

Erection Engineer

HNTB, Kansas City, Mo. (AISC Member)

Contractor

MTI (consisting of Massman Construction Co., Kansas City, Mo. (AISC Member), Traylor Brothers, Inc., Evansville, Ind. (AISC Member), IHI Corporation)

Using steel for replacement bridges to yield cost savings and environmental benefits.

Trading UP

BY STEVE NARKIEWICZ, P.E.

David Evans and Associates

SINCE 2003, the Oregon Department of Transportation has repaired or replaced hundreds of aging bridges around the state as part of the \$1.3 billion OTIA III State Bridge Delivery Program (see sidebar). Most of these are straightforward highway bridges and, from a motorist's point of view, hard to distinguish from the roadway itself. But for those charged with bringing the state's surface transportation system back up to capacity, some upgrades are proving to be more challenging than others.

From a fiscal, technical, environmental and aesthetic standpoint, replacing the two 60-year-old, seismically vulnerable, narrow bridges that carry Interstate 84 across the Sandy River near Troutdale, Ore., posed some very distinct challenges for the project team.

Located at the mouth of the world-renowned Columbia River Gorge National Scenic Area, the new bridges initially were designed as post-tensioned concrete structures each with four 200-ft spans and a total length of 800 ft. In February 2009, their estimated to-

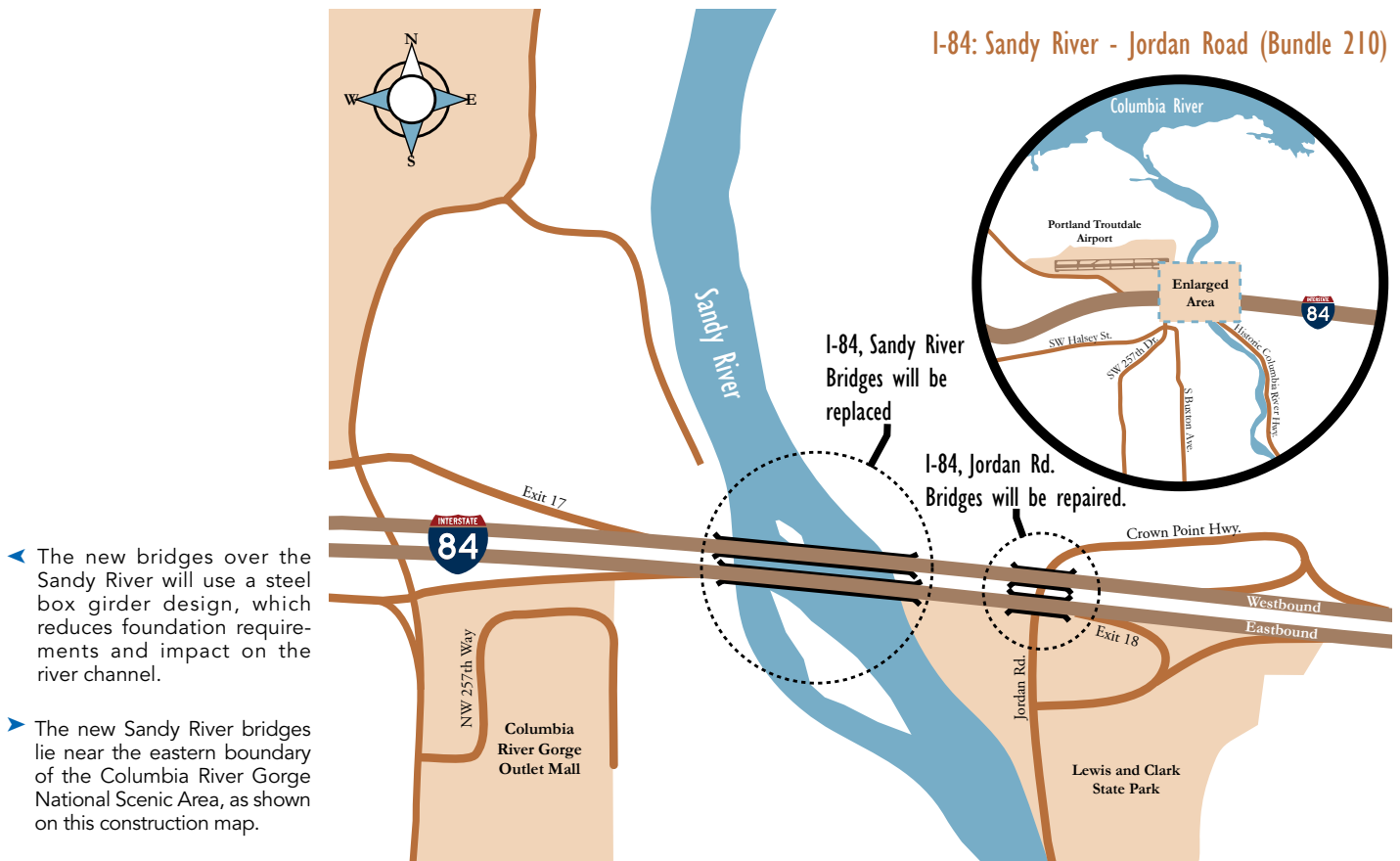
tal cost of more than \$90 million, well over the budget, triggered a complete re-evaluation of the project. An analysis of the estimate for the Sandy River bridges revealed that a large, expensive substructure would be required to support the heavy concrete superstructure.

Other bids in the OTIA III bridge program had shown that structural steel prices were declining. An economic analysis indicated that this trend was likely to continue. Faced with the conflicting goals of reducing cost and using longer spans that would protect the ecologically valuable Sandy River, which is home to threatened species such as chinook salmon, coho salmon and steelhead trout, the project team redesigned the bridges using steel box girders, abandoning the concrete design to take advantage of favorable steel prices and reduce superstructure weight.

To minimize delays to the project letting, the redesign focused on using simple repetitive details and a balance between steel weight and fabrication cost.



I-84: Sandy River - Jordan Road (Bundle 210)



- ▶ The new bridges over the Sandy River will use a steel box girder design, which reduces foundation requirements and impact on the river channel.
- ▶ The new Sandy River bridges lie near the eastern boundary of the Columbia River Gorge National Scenic Area, as shown on this construction map.

Due to the project complexity and sensitive location, ODOT used best-value bid selection criteria for this project rather than simply awarding the project to the lowest bidder. Price, qualifications and technical approach were all factors included in the scoring to determine the best value bid and selection of the contractor. Hamilton Construction Co.'s bid of \$48.5 million was not the lowest bid; however, the quality of its technical proposal gave the company the best value score.

In addition to typical budget constraints, the Sandy River Bridge project had cultural, aesthetic and technical challenges. These highly visible structures attracted interest from a number of stakeholders in the design phase.

One of the most important considerations for this project is its location in the Columbia River Gorge National Scenic Area. The CRGNSA was established by Congress to protect and provide for the enhancement of the scenic, cultural, recreational and natural resources of the gorge. ODOT worked with the Columbia River Gorge Commission, U.S. Forest Service, Federal Highway Administration, Oregon Department of Fish and Wildlife, and the three counties within the CRGNSA to develop an Interstate 84 Corridor Strategy that

would allow it to meet public safety and transportation needs while also meeting the National Scenic Area provisions.

The I-84 Corridor Strategy required the bridges to blend in with the surrounding natural environment. The final modified-contemporary design for the Sandy River bridges includes steel box girders with a rock facade on the bridge piers and abutment, and decorative pylons in dark earth-tone colors. A sleek, trim profile with a rough, rocky texture and an irregular pattern will minimize distraction and the reflectivity of various highway features. The steel box girder depths vary from 5 ft, 6 in. to 11 ft. In total, the two bridges require more than 8 million pounds of AASHTO M270 Grade 50 steel, which will be painted to comply with aesthetic guidelines.

Both eastbound and westbound bridges have spans of 200 ft, 220 ft, 220 ft and 200 ft. Proportionally shorter end spans and longer interior spans would have been preferable from a structural perspective, but the span ar-

- ▶ Redesigned from concrete to steel in late 2009 and rebid in early 2010, the Sandy River bridge construction is expected to be completed in 2013.

Steve Narkiewicz, P.E. is a consultant project manager for the OTIA III State Bridge Delivery Program with the Oregon Department of Transportation. He joined the department in 1993 as a senior geotechnical engineer, responsible for the design of the earth, rock and foundation aspects of transportation projects statewide, and since 2004 has been with ODOT's Major Projects Branch.





▲ The new Sandy River bridges will feature rock facade treatments on the bridge piers, abutments and decorative pylons consistent with the Interstate 84 Corridor Strategy aesthetic design guidelines.

rangements chosen keep the substructures out of the low-flow channel and avoid the existing bridge foundations.

The eastbound bridge includes a 16-ft-wide multi-use path. This feature, unusual for an interstate highway bridge, was included to allow pedestrians and bicyclists to safely gain access to popular recreation areas in the Columbia River Gorge. Both bridges have three 12-ft lanes and two 12-ft shoulders.

Environmental and seismic issues were a challenge regardless of the materials selected, but changing the design of the superstructure to steel girders provided a number of benefits in these areas.

Because the Sandy River is home to chinook salmon, coho salmon and steelhead trout, all of which are threatened species, ODOT was required to reduce the environmental impact of the project both during and after construction. One of the team's design goals was to open the channel so that the fluvial geomorphology could return to a more natural state.

Environmental regulatory agencies requested longer bridges without additional substructures, which would further open

the channel to provide better fish habitat. Piles placed to support falsework were a concern because completely removing the long piles located below the new bridges would be impractical. Leaving the piles in place would conflict with the goal of restoring the channel to a more natural condition. By building with steel, the amount of falsework the bridge crew will develop for the bridge structure will be notably less than what would have been used for concrete, because only one tower will be needed on each side to erect the girders.

During construction, strict limits will also be imposed on the volume of material, including fill and concrete, that can be placed in the channel. Construction activities within the area of the ordinary high water are limited to a six-week period each year.

Foundation conditions at the site can only be described as challenging from a design perspective. The bridge rests in a seismically active area with more than 100 ft of loose, saturated sand overlying the bedrock at the site. Because lateral forces that develop during an earthquake increase with the mass of the superstructure, the po-

tential for soil liquefaction during a seismic event was analyzed extensively during design. Reducing the superstructure mass and weight not only helped to reduce potential seismic impacts, but also shrank the drilled-shaft size from the 10 ft diameter required for the concrete design to 8 ft for the steel bridges. Building smaller shafts also helped meet the environmental requirement to reduce the volume of material removed and replaced within the channel. These reductions lowered costs as well.

In the end, our reworking of the design plans included only two visible differences between the steel and concrete versions of the bridges. The first is that with concrete there would have been two box surfaces underneath the bridge, and with steel there will be three or four. The new steel bridges will also be 40 ft longer to the east to widen the channel, which helps diminish environmental impacts.

With all of these reductions in environmental impact, construction cost and overall bridge load, the decision to redesign the bridges with steel girders has proven to be very beneficial to the

- The eastbound bridge over the Sandy River will include a combined bicycle and pedestrian crossing that will accommodate users traveling in both directions.



David Evans and Associates

agency. With a completion date slated for 2013, we look forward to seeing travelers through the Columbia River Gorge benefit from the bridges' replacement for decades to come.

MSC

Project Owner

Oregon Department of Transportation

Designer and Structural Engineer

David Evans and Associates, Inc.,
Portland, Ore.

Steel Fabricator

Mountain States Steel, Lindon, Utah
(AISC and NSBA Member)

Contractor

Hamilton Construction Company,
Springfield, Ore. (AISC and NSBA
Member)

Oregon's Big Investment

The 10-year, \$3 billion Oregon Transportation Investment Act (OTIA) marked the largest construction investment in the state's highway and bridge system since creation of the interstate highway system began in the 1950s.

OTIA I and II, passed in 2001 and 2002, respectively, resulted in \$500 million in improvements to state transportation infrastructure. Most projects in these programs were opened to traffic by 2009.

The third phase of the program, OTIA III, was enacted in 2003. The \$2.46 billion package allocated \$1.3 billion to repair or replace Oregon's aging state highway bridges and \$1.16 billion to fund county and city maintenance projects, local bridge repair and replacement work, and modernization projects statewide.

The majority of the OTIA III bridges are now complete and open to traffic. All but two of the remaining bridges will be in construction by 2011.





Highway Braid Made From Steel

BY JIM WERST, P.E.

When space is tight, the adaptability of steel enables the design to minimize the inconvenience of construction.

HOW CAN YOU ACCOMMODATE large volumes of vehicles merging and weaving in dense rush hour traffic when you run out of real estate? And how could highway planners do this without traffic moving at a snail's pace? For this busy segment of I-435 in Overland Park, Kan., the solution was to construct "braided ramps" to allow cars and trucks to move toward different destinations without having to yield to each other. The challenge of fitting these crisscrossing (or braided) lanes into a small space adjacent to Indian Creek, an existing golf course, and a residential neighborhood was a significant one for the highway and bridge designers at the Kansas Department of Transportation and HNTB Corporation.

These braided ramps are situated for the westbound entrance-ramp for traffic entering I-435 at the new interchange at Antioch Road. This new five-span steel girder bridge allows traffic to join I-435 without weaving with vehicles exiting I-435 to get to US 69. Key challenges for the bridge designers included limited space (both horizontal and vertical), an extremely large skew angle at the intersecting roadways, the sequence of bridge erection, and minimizing adverse impacts to the adjacent creek, golf course, apartment complex, and park trail.

The solution chosen to unclog a potential bottleneck without taking new right-of-way was part of a larger \$130 million highway improvement administered by the Kansas DOT in cooperation with the city of Overland Park and constructed by Kansas City-based Clarkson Construction Company. Improvements built over a three-year period, beginning in the middle of 2006, included a new interchange at I-435 and Antioch Road, widening of I-435 between Antioch Road and Metcalf Avenue, and capacity enhancements via collector-distributor (CD) lanes and new ramps at the US 69 interchanges with I-435 and 103rd Street.



- ▲ Using steel girders helped control the cost of temporary falsework supports and facilitated construction of integral post-tensioned concrete cap beams. Note the narrow site.
- By intertwining ramps in a braid-like fashion, designers were able to add entrance and exit ramps in the narrow space between an existing apartment complex and highway without endangering motorists with crisscross traffic patterns.

Steel plate girders achieved the multiple objectives that designers established for this bridge solution. The bridge girders needed to be relatively light to control costs of temporary falsework supports. And the girders needed to be continuous over three interior pier supports to accommodate another feature of this bridge—inte-



Jim Werst, P.E., is a bridge project manager for HNTB Corporation. A 1980 graduate of the University of Missouri, Columbia, he has been with HNTB for 30 years.



Steel Bridge NEWS



▲ ▼ The steel girders were supported by falsework (above) until the concrete cap beam was cast and cured and post-tensioning was completed.



gral post-tensioned concrete cap beams. In order to reduce the height of the bridge by several feet, the steel I-girders were framed in with the concrete cap beams at three of the four interior piers. Steel girders were supported by falsework until the concrete cap beams were cast and cured and post-tensioning was completed. Post-tensioning provides extra strength, limits beam deflections, and provides crack control where the steel girders pass through the cap beam.

The east and west tee-piers (Piers 1 and 3) adjacent to the straddle bent also use this configuration of steel girders framed within the post-tensioned concrete cap beam. This was done to allow the pier cantilever to extend out over the ramp shoulder without requiring additional vertical separation of the upper and lower profiles. This geometry maintains a favorable perpendicular alignment between substructure and superstructure and reduces the span length required to braid the two ramps. With the crossing angle of nearly 80°, the interior spans would have to be lengthened more than 50% to position the outside piers clear of the lower roadway.

The 38-ft-wide bridge roadway carries two lanes of traffic and crosses a two-lane

- Use of a straddle bent permits vehicles to exit without having to merge right through traffic entering the highway.

roadway underneath at a skew angle of almost 80°. With this extreme angle at the intersecting lanes, a structure length of approximately 700 ft was required to provide vertical separation and associated clearances. Span lengths for the welded plate I-girders are 131.2 ft, 167.3 ft, 167.3 ft, 131.2 ft and 98.4 ft. A web depth of 67 in. was used for the composite steel girders spaced at 8.6 ft on center. All steel was painted Grade 50.

Although the innovative choice of three integral framed-in pier cap beams added a higher degree of complexity to the erection of the bridge superstructure, it also provided appealing benefits. Traffic on the lower roadway passes through a “straddle bent” at Pier 2 and underneath the overhanging cantilevers of the “tee” piers at the end of each adjacent span. This arrangement offered relatively shorter spans and reduced the overall height of the bridge while allowing all pier and abutment supports to be positioned normal to the bridge. This uniform substructure arrangement resulted in a very regular geometry for the steel framing system and provided a cost savings over alternate schemes that would have used longer spans, unbalanced spans, and/or variable skews with unequal girder lengths.

It was important to strategically plan the sequence of construction for the entire project early in the design phase with careful attention to requirements of this unique grade separation before deciding on the final bridge type. Most importantly, traffic could not be placed on the new lower roadway until temporary falsework for the new bridge could be removed. Also, an objective established by the Kansas DOT required that traffic conditions improve as each stage of construction was completed. HNTB designers were able to develop a construction sequence that accomplished both of these objectives.

HNTB produced a 3D computer animation during the design phase to help state and city officials, as well as the public, better visualize how this segment of the highway system would appear from the driver’s perspective. One important design objective was to avoid a “tunnel effect” for drivers that would create a sense of claustrophobia or discomfort resulting from limited sight distance. Public input was proactively sought throughout the process, resulting in context-sensitive solutions consistent with the goals of the project. Ultimately, the project’s success was founded on dedication to partnering from beginning to end.

Much planning went into the desired aesthetics for the improvements for this busy highway corridor in a growing suburb of the bi-state Kansas City metropolitan area. It was important that the bridge type selection at this site also provide continuity of architectural features that would ensure that it fit in well with the overall surroundings. This was achieved with concrete form liner and color coatings used on the bridge piers, barriers, and for the mechanically stabilized earth (MSE) retaining walls that meet the bridge at both ends. Surface texture and dark earth tones were applied to the precast concrete sound barriers that helped provide both a noise and visual screen for the heavily treed neighborhoods along the highway.

Working with the engineer and the contractor to con-



▲ To reduce the height of the bridge by several feet, the steel I-girders were framed in with the concrete cap beams at three of the four interior piers.

struct the new interchange at Antioch Road, widen I-435, and modify the I-435/US 69 and 103rd Street/US 69 interchanges, the Kansas DOT and the city were able to reduce congestion, increase safety and improve access along this very important corridor. Through early and ongoing collaboration among these project planners and builders, the completed project now benefits state and city agencies, the local community and the commuters who use the facility every day.

MSC

Owner

Kansas Department of Transportation

Designer

HNTB Corporation, Overland Park, Kan.

Steel Fabricator

Hirschfeld Industries - Bridge, Colfax, N.C. (AISC and NSBA Member)

General Contractor

Clarkson Construction Company, Kansas City, Mo.



Using steel offered economic and scheduling advantages, as well as the opportunity to reuse salvaged materials.

New Spans Over Two Oregon Rivers

BY PETER PAGTER, S.E., P.E., AND XIQIN LONG, P.E.

DOUGLAS COUNTY, OREGON, had a unique opportunity to replace two long-span bridges just 20 miles apart over the very environmentally-sensitive South Umpqua and North Umpqua rivers with locally-fabricated weathering structural steel plate girders. This was an unusual opportunity because most highway bridges in the state are constructed with prestressed concrete elements.

South Umpqua River (Pruner Road) Bridge

The old South Umpqua (Pruner Road) Bridge, constructed in 1957, was a cast-in-place concrete bridge with a longitudinally and transversely post-tensioned main span. The superstructure showed signs of severe deterioration, and both Douglas County and the Oregon Department of Transportation (ODOT) decided it was critical to replace the old bridge.

Replacement design efforts had to account for both traffic and seismic demands. The average daily traffic (ADT) was estimated to be 6,850 vehicles per day in 2008 and is forecasted to be 9,180 by 2027. The seismic site peak acceleration coefficients (A) are 0.13g and 0.22g for the 500-year and 1,000-year return periods, respectively. It is interesting to note that the acceleration coefficients increase by a factor of three just 45 miles to the west along the Oregon coast.

The new Pruner Road Bridge is a 588-ft-long three-span bridge composed of four weathering structural steel plate girder lines. The unbalanced spans of 200 ft, 218 ft, and 170 ft were chosen to avoid the existing footings of the old bridge. In order to find the most efficient use of steel, the designer analyzed several girder configurations. The final girder spacing is 12 ft—well within the ODOT guidelines of 11 ft to 14 ft for spans

longer than 140 ft. The four lines of weathering steel girders, conforming to ASTM Specification A709 Grade 50W, are 80 in. deep.

The interior piers are supported on 7-ft-diameter drilled shafts to minimize the substructure excavations in the environmentally sensitive river. The concrete bridge rails incorporated ashlar stone architectural treatment, and the steel top railings were powder-coated brown to provide increased aesthetic appeal.

The advantages of selecting a structural steel bridge over the precast post-tensioned segmental concrete alternative were:

- Smaller foundations due to a lighter superstructure
- Future widening is more constructible
- Shorter construction time, reducing temporary impacts to the river
- Less disruption to the traveling public due to shorter construction time

The projected costs during the preliminary design phase for the three structure alternatives were:

- Structural steel bridge with detour bridge: \$8,828,000
- Post-tensioned concrete bridge with detour bridge: \$8,223,000
- Staged structural steel bridge (no detour bridge): \$9,967,000

Douglas County chose the unstaged structural steel alternative with the detour bridge because of lower project costs, as well as the items listed above. [The Detour Bridge](#)

The existing 627-ft-long, seven-span North Umpqua River (Brown) Bridge, constructed in 1965, had a cast-in-place concrete box girder main span with prestressed concrete deck gird-

- ◀ The new 588-ft-long South Umpqua River (Pruner Road) Bridge uses four weathering structural steel girders spaced 12 ft apart.
- ▶ The new South Umpqua River (Pruner Road) Bridge features aesthetic treatments including a brown powder-coating on the steel top railings.



OBEC Consulting Engineers



OBEC Consulting Engineers

er approach spans. The bridge had developed several structural deficiencies in recent years, including extensive shear cracks up to 0.06 in. and flexure cracks up to 0.07 in. in the main span. Furthermore, the bridge had developed negative camber over the past decade.

As a result, the existing bridge was load-restricted and required monthly inspection monitoring. The condition of the bridge was so deteriorated that the geotechnical drilling equipment was not allowed on the center spans to provide exploratory investigation in the main part of the channel.

When the structural condition worsened in 2008, Douglas County declared the replacement of the bridge an emergency. OBEC Consulting Engineers quickly designed a 760-ft-long temporary detour bridge to be constructed adjacent to the permanent replacement bridge. The project was designed in two months and bid in April of 2008. The successful bidder's total contract was for \$1,247,000.

The temporary detour bridge was designed as a 12-span structural steel bridge with 40- to 60-ft-long approach spans and one 125-ft-long main span. During the design phase of the detour bridge, the county provided several ideas to promote the concept of sustainability. The main steel girder

On-Site Concerns

The site of the old South Umpqua River Bridge is well known as an archaeological hot spot for Native American artifacts. There are known Native American archaeological sites along the North Umpqua River as well, so the entire project required close monitoring by local tribes during construction.

Additionally, the North Umpqua River is very environmentally-sensitive, with some of the most productive coho and steelhead salmon runs within the state. The coho salmon that frequent these waters became federally-listed as an endangered species during construction. That further complicated the environmental documentation and required an emergency consultation with the National Marine Fisheries Service.

Peter Pagter, S.E., P.E., and Xiqin Long, P.E., are senior project engineers with OBEC Consulting Engineers, Eugene, Ore., and Professional Members of AISC. Pagter has more than 27 years of experience designing bridges of all types in Oregon. Long also is a member of the Society of Women Engineers and has more than 16 years of experience designing bridges and other structures.





OBEC Consulting Engineers

- ◀ To give the new highly-visible North Umpqua River (Brown) Bridge more visual appeal, the structure features haunched weathering structural steel girders and an ashlar stone architectural treatment at the interior pier. In addition, all visible concrete surfaces are stained with three different colors.



OBEC Consulting Engineers

spans of the detour bridge were salvaged and modified from an earlier local bridge replacement, and several approach spans incorporated salvaged beams from the county's bridge maintenance yard stockpile, saving the county from having to purchase new beams. The design included locally fabricated precast concrete deck panels and steel bridge rail, all of which are planned to be disassembled and used at different sites after the permanent bridge has been constructed.

For a county with more than 300 bridges, there are numerous benefits that result from designing reusable, sustainable bridge elements. Many of Douglas County's bridges are nearing the end of their useful life, and the county anticipates reusing all of the deck panels and steel girders from the temporary bridge on future bridge replacement projects. The salvaged structural elements can be easily stockpiled and take up much less room in the county storage yard than concrete girders. With the lighter overall weight, they also are more easily handled by smaller equipment, which frees up the county to deploy them more rapidly, especially in the event of an emergency repair. The steel elements in particular represent a built-in cost savings that will help the county make the most of limited resources because the engineering details can be easily transferred to another site.

Because hard pile-driving conditions were anticipated during construction, OBEC designed the substructure with a four-pile braced bent system with inside-fitting cutting shoes and 24-in.-diameter steel pipe piles. One-in.-diameter high-strength rock anchors were planned, but the piles were sufficiently embedded into the alternating layers of sandstone and siltstone that the rock anchors were not necessary.

To speed up construction, the contractor employed two cranes at opposite ends of the river to drive piling and erect the superstructure. As each span was constructed, the cranes moved across the completed span to start construction on the next span. The contractor used this "trestle" construction method to eventually meet in the middle of the bridge.

North Umpqua River (Brown) Bridge

The design of the replacement North Umpqua River (Brown) Bridge was completed during construction of the South Umpqua

- ▲ Douglas County and the Oregon Department of Transportation considered concrete and steel alternatives for the permanent North Umpqua River (Brown) Bridge, but ultimately chose the structural steel option. To increase the structure's aesthetics, OBEC Consulting Engineers designed the bridge to utilize haunched steel girders at its interior piers.

- ▼ This artist's rendering was used during preliminary design to demonstrate what the final North Umpqua River (Brown) Bridge would look like.



OBEC Consulting Engineers

Steel Bridge NEWS




▲ The North Umpqua River detour bridge being constructed adjacent to the existing bridge. The steel girders for the 120-ft main span were salvaged and modified from a local bridge replacement.

▲ Workers install the precast concrete panels that make up the deck of the temporary North Umpqua River detour bridge. Douglas County plans to reuse the deck panels and steel bridge rail at different sites after the permanent bridge is complete.

River (Pruner Road) Bridge and the temporary North Umpqua River (Brown) Detour Bridge. The two new bridges are similarly configured, with three spans and four lines of weathering steel girders. Whereas the South Umpqua River Bridge has straight (unhaunched) girders, the North Umpqua River Bridge has haunched girders at the interior piers. The 646-ft-long bridge has asymmetrical spans of 200 ft, 250 ft, and 196 ft in part to avoid existing footings and also to allow the contractor to use the existing substructure to help erect the new superstructure.

A precast post-tensioned segmental concrete alternative was studied during the preliminary design phase, and the estimated cost of construction for the two alternatives was:

- Structural steel bridge: \$13,079,000
- Post-tensioned concrete bridge: \$13,425,000

These estimates included construction engineering and contingencies. Douglas County and ODOT decided to pursue the structural steel alternative for several reasons. First, they determined that the concrete alternative required two 8-ft-diameter drilled shafts to resist the calculated seismic forces, while the steel alternative required 7-ft-diameter shafts, reducing the environmental impact. Second, any future widening of the bridge would be easier with a steel bridge.

In 2008, the ADT was measured to be 5,459 vehicles per day, but is anticipated to

be 12,090 by the year 2031. The seismic site peak acceleration coefficients (A) are only slightly higher than they are for the South Umpqua River Bridge: 0.14g and 0.24g for the 500-year and 1,000-year return periods, respectively.

The girder spacing is 13 ft 6 in., just within the ODOT-recommended maximum girder spacing of 14 ft. The roadway widens from 40 ft to 50 ft in Span 3 to allow traffic storage for turning movements on Old Garden Valley Road north of the bridge.

Because of the North Umpqua River Bridge's high visibility, the county wished to add aesthetic features. Haunched girders and arched interior piers give the new bridge an attractive appearance, while all visible concrete surfaces are stained with three different colors and incorporate an ashlar stone appearance.

The project was bid in May 2009. The total cost of construction was \$5,362,000. Steel prices for weathering structural steel were relatively low during the design and construction of both Umpqua Basin bridges, providing substantial cost savings for the county. For the South Umpqua River (Pruner Road) Bridge, the price for the structural steel was \$1.58 per pound, and \$1.40 per pound for the North Umpqua River (Brown) Bridge, including fabrication, transportation, and erection.

Conclusion

Douglas County was looking for cost-effective, low-maintenance long-span

bridges to replace two of its aging structures over the South and North Umpqua rivers. Weathering structural steel bridge replacements provided all the answers in the environmentally sensitive Umpqua Basin. The new South Umpqua (Pruner Road) Bridge and North Umpqua River (Brown) Bridge will maintain these vital transportation links for county residents and others for many years to come. **MSC**

Owner

Douglas County, Oregon

Structural Engineer

OBEC Consulting Engineers, Eugene, Ore.

Steel Detailer and Fabricator (Pruner Road and Brown Bridges)

Fought & Company, Inc., Tigard, Ore. (AISC and NSBA Member)

Steel Erector (Pruner Road and Brown Bridges)

REFA Erection, Inc., Tigard, Ore. (IMPACT Member)

General Contractor — South Umpqua (Pruner Road) Bridge

Ross Bros. & Co., Inc., Salem, Ore.

General Contractor — North Umpqua (Brown) Bridge

Concrete Enterprises, Stayton, Ore.

General Contractor — North Umpqua River Detour Bridge

Carter & Co., Salem, Ore.



Rapid, *Economical* Bridge Replacement

BY GEETHA CHANDAR, P.E., MICHAEL D. HYZAK, P.E., AND LLOYD M. WOLF, P.E.

Shallow trapezoidal steel box girders provide a highly constructible, light and efficient structure.

WITH THE NORTH AMERICAN FREE TRADE AGREEMENT (NAFTA) spurring commerce, the Texas Department of Transportation (TxDOT) is intent on upgrading transportation routes. Part of this effort is a multi-year corridor improvement plan to expand the four-lane I-35 to six lanes. I-35 stretches 1,565 miles from Laredo, Texas to Duluth, Minn., including 500 miles within the state of Texas. The massive project includes upgrades of many of the overpasses along the route, offering bridge engineers both challenges and opportunities.

One of these projects is the FM 3267 bridge. Located 75 miles north of Austin on one of the busiest segments of the nation's interstate highway system, the project offered the challenge of how to span the widened highway without raising the approaches and still maintaining the required vertical clearance.

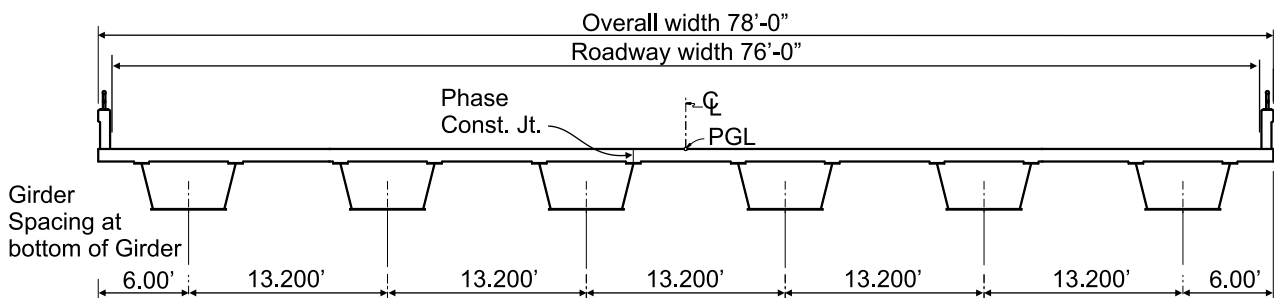
One project goal was to create a signature design aesthetic while providing a rapidly constructible and cost-efficient structure. The interior bent caps were eliminated in order to accelerate the construction. The shallow superstructure, in conjunction with the inclined exterior pier faces and lack of interior bent caps, provides an attractive structure from all views. The

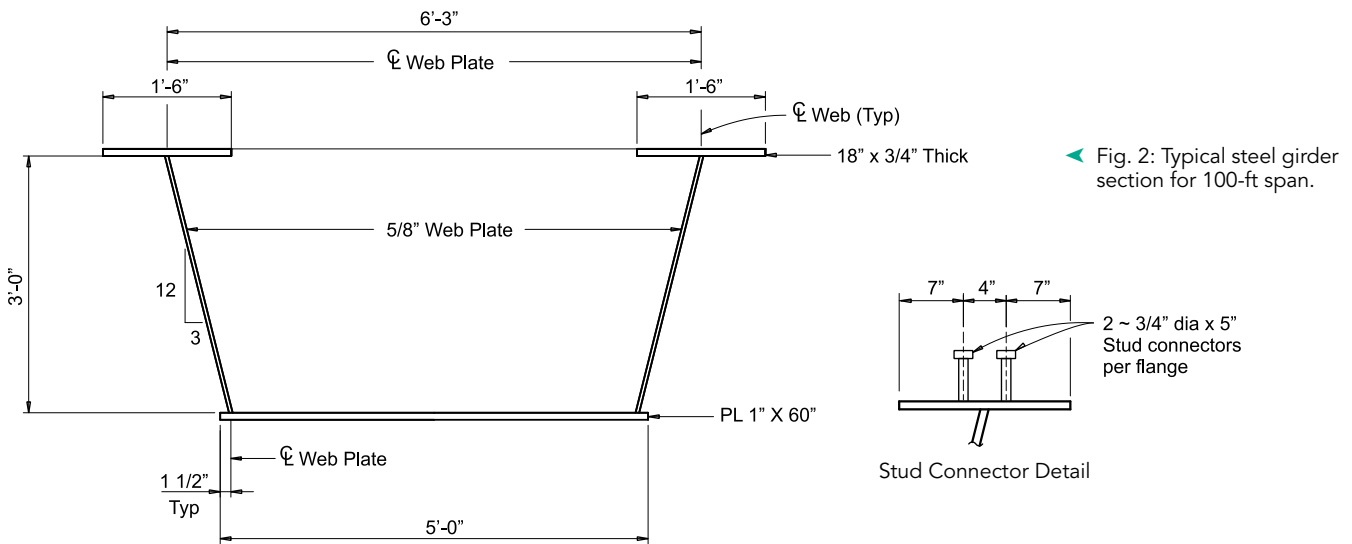
structural efficiency provided by trapezoidal steel girders allowed them to be proportioned to meet the required depth and strength requirements.

One of the design challenges for this bridge was minimizing girder depth as much as possible. Several superstructure options were considered, including prestressed concrete U-beams, I-beams and steel plate girders. The system chosen features single columns under each shallow trapezoidal steel box girder and simple spans of 45, 100, 100 and 65 ft. The structural efficiency provided by trapezoidal steel girders allowed them to be proportioned to meet the required depth and strength requirements.

The bridge has an overall width of 78 ft, carries a roadway width of 76 ft., and uses six lines of 36-in.-deep steel box girders at 13.2-ft centers with 6-ft overhangs. A cast-in-place deck was constructed in two phases with a longitudinal joint in the deck on top of one of the girder flanges.

The girder sections were standardized and common details saved design, fabrication and erection costs. Figure 1 illustrates a typical transverse girder section that has a span capability of 100 ft. The 45-ft and 65-ft spans have a typical steel girder section con-

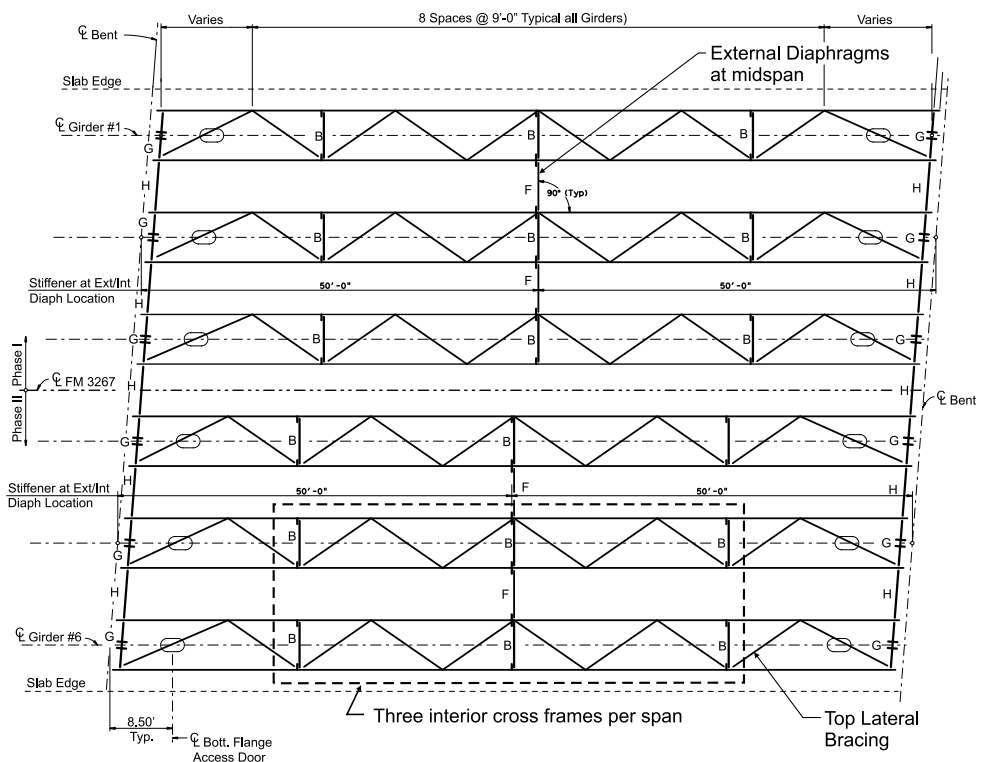




sisting of 36-in. web plates, two 18-in. \times $\frac{3}{4}$ -in. top flanges and a 60-in. \times $\frac{3}{4}$ -in. bottom flange. The 100-ft span has 36-in. web plates, 18-in. \times $\frac{3}{4}$ -in. top flange and 60-in. \times 1-in. bottom flange. Figure 2 shows the typical steel girder section for 100-ft span. The girder is designed according to the 2004 AASHTO *LRFD Bridge Design Specifications*. The girder is designed as a compact composite section and is checked for ultimate strength, service stress and deflection. The strength controls the design of the 100-ft span steel girder section.

The maximum span/total depth ratio is approximately 25. The top and bottom flanges of tub girders are designed primarily to carry the girder bending stresses. Top flanges also are subjected to significant lateral bending stresses that were generated by sloping webs and temporary supporting brackets for slab overhangs. In addition, top flanges also are subjected to erection loads, as most contractors lift steel girder sections by clamping to the top flanges.

The design includes three interior cross frames (Diaphragm-Type B) per span. There is an internal K-frame located at 9-ft spacing throughout the span. Figure 3 shows the framing plan



▲ Fig. 3: Framing plan with cross frames and diaphragms.

Geetha Chandar, P.E., is a bridge design engineer and has been with the Texas DOT for six years, after four years as a structural engineer in the private sector. Michael D. Hyzak, P.E., is also a bridge design engineer with TxDOT, where he has designed numerous types of highway and railroad structures over the past 12 years. Lloyd M. Wolf, P.E., is a bridge engineering group leader in the TxDOT Austin Headquarters, Bridge Division, where he has been engaged in highway and railroad bridge design for 23 years.



Steel Bridge NEWS



Michael L. Ford, Bridge Division, TXDOT

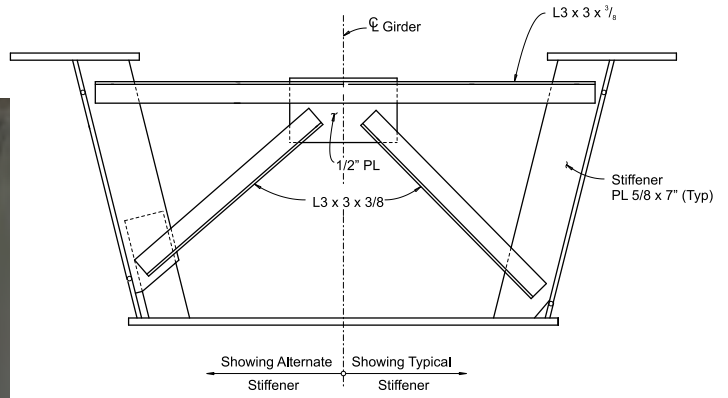


Fig. 4: Interior K-frame details.

with cross frames and diaphragms. Figure 4 shows the interior K-frame details. An external diaphragm with W21×44 at the middle of each span was left for future redecking.

Two types of external bracing are typically used for steel box girders, K-type cross frames and solid diaphragms. Typically solid diaphragms only have been used at support areas, on skewed bridges. The external end diaphragms at the supports have access manholes for future inspection. Figure 5 shows the end diaphragm (Type H). The internal diaphragms at the supports are full-depth plate girder sections. The diaphragms are supported by two bearing stiffeners. The bearing supports provide better torsional resistance and induce less bending stress in the internal diaphragms. Top flange lateral bracing is designed to form the top side of the box girder until the slab is in place. Providing a lateral bracing system increases the torsional stiffness of the tub girders. Figure 6 shows the internal diaphragm (Type G).

The design makes use of ASTM A709 Grade 50W weathering steel, specified for its durable performance with low maintenance costs. The drip tabs and other details are provided to reduce the potential for substructure staining from the weathering steel.

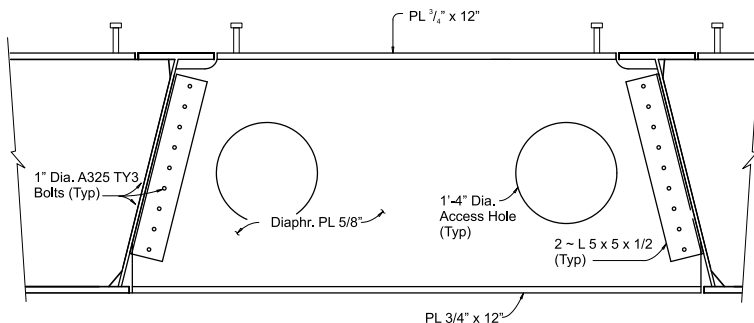
Girder erection and deck placement were accomplished during several nighttime road closures. The steel box girders were erected individually and connected with end diaphragms and cross frames between pairs of stiffeners. The elimination of field splices reduced erection time and minimized traffic disruption. The deck is continuous over the interior piers, providing a jointless, low-maintenance 310-ft-long bridge.

Simple laminated elastomeric bearings are used at the supports. The columns were cast-in place with a formliner to give the appearance of large limestone blocks. Outer columns were designed with tapered width for added aesthetic value. The four-



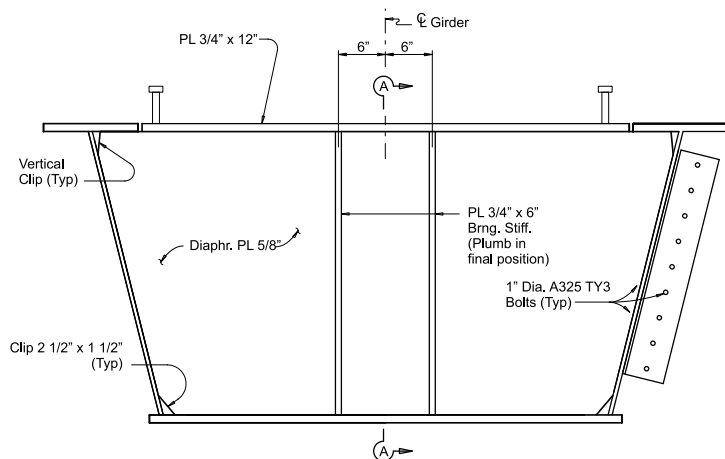
Michael L. Ford, Bridge Division, TXDOT

Fig. 5: End diaphragm.



Michael L. Ford, Bridge Division, TXDOT

Fig. 6: Internal diaphragm.





Michael L. Ford, Bridge Division, TXDOT

- ▲ Because of the steel box girders' light weight and wide spacing, each could be supported on individual columns, which eliminated the need for a bent cap.

dations consist of one 30-in.-diameter drilled shaft at each interior pier and two 30-in.-diameter drilled shafts at the end piers. Due to the wide spacing of girders and the light weight of the steel box girder, each girder was able to be directly supported on individual columns, eliminating the need for a bent cap, which also reduced the construction time.

Choosing weathering steel also reduces future maintenance. Careful detailing of drip rails and stainless steel pans under the bearings prevents staining of the pier elements. The girders were abrasive-blasted to remove mill scale and to provide a uniform weathered appearance. The interior of the girders was shop-coated white to enhance visibility during routine inspections.

The clean lines of the bridge and the contrast between the dark, weathered steel and the white concrete rail and pier elements provide an attractive solution. The rapid construction of the interior bents, without caps, and the shallow steel box girders, without field splices, minimized the construction time and work zone duration.



Hirschfeld Industries

- ▲ Side elevation of the completed bridge.

This also provided the necessary span length and satisfied the available superstructure depth limitations.

The FM 3267 bridge was let in June 2006, along with the Old SH 81 bridge in a contract that also contained a steel plate girder bridge along with roadway, drainage and numerous other items typically contained in a large highway project. Construction was essentially complete as of August 2010.

MSC

Owner

Texas Department of Transportation

General Contractor

W.W. Webber Inc, Houston

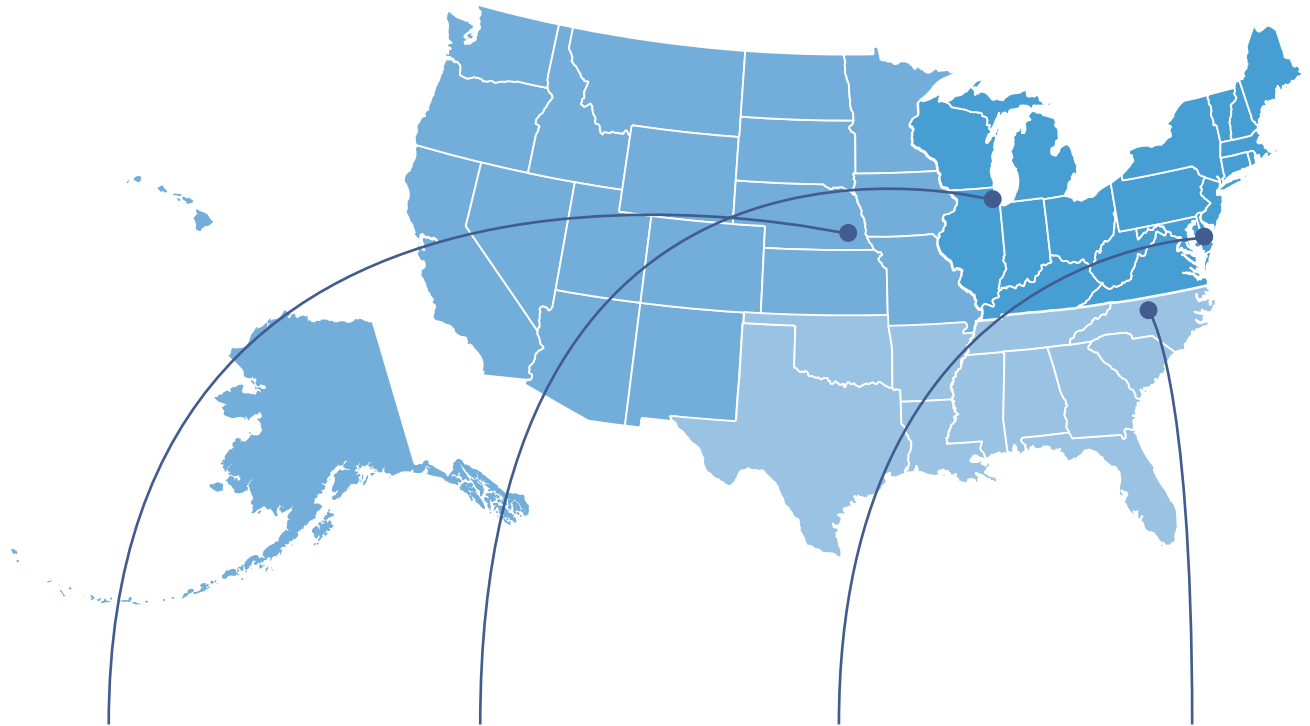
Steel Fabricator

Hirschfeld Industries, San Angelo, Texas (AISC and NSBA Member)

Contact Us

NATIONAL STEEL BRIDGE ALLIANCE

a division of American Institute of Steel Construction



EAST

Calvin Schrage
NSBA Regional Director

Lincoln, NE
schrage@steelbridges.org
(402) 466-1007

NSBA HEADQUARTERS

1 E. Wacker Dr. Ste. 700
Chicago, IL 60601

Roger Ferch
Executive Director

(312) 670-5401

Brian Raff
Marketing Director

raff@steelbridges.org
(312) 670-5415

NORTHEAST

Bill McEleney
NSBA Director

Cranston, RI
mceleney@steelbridges.org
(401) 943-9660

SOUTHEAST

**Christopher Garrell,
P.E., LEED AP**
NSBA Regional Director

Cary, NC
garrell@steelbridges.org
(484) 557-2949



There's always a solution in steel.

American Institute of Steel Construction
One East Wacker Drive, Suite 700
Chicago, IL 60601

312.670.2400 www.aisc.org



National Steel Bridge Alliance
A division of American Institute of Steel Construction
One East Wacker Drive, Suite 700
Chicago, IL 60601

312.670.2400 www.steelbridges.org